

**DL5600**  
**DOT MATRIX PRINTER**  
**USER'S MANUAL**

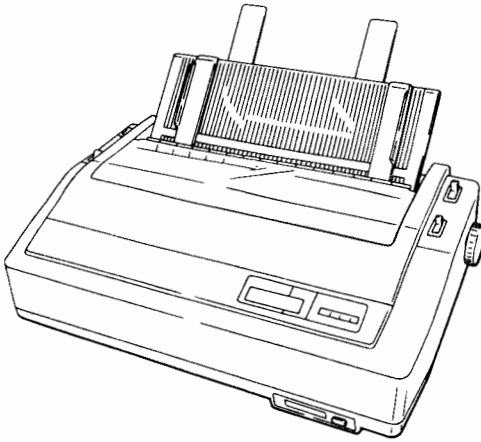

# Federal Communications Commission Radio Frequency Interference Statement for United States Users

This equipment generates and uses radio frequency energy. If it is not installed and used properly, that is, in strict accordance with the manufacturer's instructions, it may cause interference to radio and television reception. It has been type tested and found to comply with the limits for a Class B computing device in accordance with the specification in Subpart J of Part 15 of FCC Rules, which are designed to provide reasonable protection against such interference in residential installation. However, there is no guarantee that interference will not occur in a particular installation. If this equipment does cause interference to radio or television reception, which can be determined by turning the equipment off and on, the user is encouraged to try to correct the interference by one or more of the following measures:

- Reorient the receiving antenna.
- Relocate this equipment with respect to the receiver.
- Move this equipment away from the receiver.
- Plug this equipment into a different outlet so that this equipment and the receiver are on different branch circuits.

If necessary, the user should consult the dealer or an experienced radio/television technician for additional suggestions. The user may find the following booklet prepared by the Federal Communications Commission helpful:

"How to identify and Resolve Radio-TV Interference Problems."

This booklet is available from the US Government Printing Office, Washington, D.C., 20402, Stock No. 004-000-000345-4.

(This equipment has been tested as M3359A of the model number.)

## NOTES:

1. The use of a non-shielded interface cable with the referenced device is prohibited. The length of the interface cable must be 3 m or less.
2. The length of the power cord must be 3 m or less.

## Notice for German Users

Dieses Gerät entspricht als Einzelgerät den  
Funkstörungsanforderungen der Postverfügung Nr. 1046/1984 bz  
der Grenzfläche B nach VDE 0871/6.78.

Das Kabel muß abgeschirmt und unter 3 Meter lang sein.

## \*\*\*\* TRADEMARK ACKNOWLEDGEMENT \*\*\*\*

Centronics is a trademark of Centronics Data Computer Corporation.  
IBM PC, IBM Graphics Printer, and IBM Proprinter XL are trademarks of  
International Business Machines Corporation.

Fujitsu FX-100 and JX-80 are trademarks of Seiko Epson Corporation.  
Diablo 630 API and Diablo 1640 are trademarks of Diablo Systems  
Incorporated.

BDT is a trademark of Büro und Datentechnik GmbH.

**B-69337 Rev. B July 1987**

The contents of this manual may be revised without prior notice.

© Copyright 1987 by Fujitsu Limited. Printed in Japan. All rights  
reserved. No part of this manual may be reproduced in any form without  
permission.

Address comments concerning this manual to:

FUJITSU AMERICA INC.

55 Orchard Drive,  
San Jose,  
California 95134-2017, U.S.A.  
TEL: (1-408) 432-1300  
TLX: 176207  
TWX: 910-338-2193

or

FUJITSU AUSTRALIA LTD.  
41 McLaren Street,  
North Sydney, N.S.W. 2060,  
Australia  
TEL: (61-2) 959-6555  
TLX: 25233

or

FUJITSU EUROPE LTD.  
2, Longwalk Road,  
Stockley Park,  
Uxbridge,  
Middlesex UB11 1AB,  
England  
TEL: (44-1) 573-4444  
TLX: 263871

or

FUJITSU NORDIC AB  
Torggatan 8,  
171-54, Solna,  
Sweden  
TEL: (46-8) 764-7690  
TLX: 13411

or

FUJITSU DEUTSCHLAND GmbH.  
Friedrichstrasse 14,  
6000, Frankfurt am Main 71,  
F.R. Germany  
TEL: (49-69) 66-40020  
TLX: 5213994

or

FUJITSU ITALIA S.p.A.  
Via Melchiorre Gioia, 8,  
20124 Milano,  
Italy  
TEL: (39-2) 657-2741  
TLX: 350142

## \*\*\*\* PREFACE \*\*\*\*

This manual represents the FUJITSU DL5600 Dot Matrix Printer as manufactured at the time of publication.

The specifications of the printer models differ with combinations of three features and country: color printing, RS-232C serial interface, automatic paper thickness controller (APTC), and country.

Every effort has been made to ensure that the information included here is complete and accurate. Fujitsu has reviewed this material but cannot be held responsible for errors and omissions.

Fujitsu has other publications for this printer, as listed on the following page. Please request additional publications from your dealer or authorized Fujitsu representative.

We reserve the right to make changes and improvements to this product without obligation to incorporate these changes and improvements into units previously shipped.

## \*\*\*\* SUPPLIES, OPTIONS AND PUBLICATIONS \*\*\*\*

The following items are available for your printer. Contact your Dealer or Fujitsu representative for additional information.



### SUPPLIES:

#### Ribbon Cassette

Color (D30L-9001-0273)

Black (D30L-9001-0269)

#### Ribbon Subcassette (not available for U.S. users)

Color (D30L-9001-0296)

Black (D30L-9001-0259)

### OPTIONS:



#### Font Cards

Orator/Light Italic 12 (D05B-2610-C711)

Scientific 12/Letter Gothic 12 (D05B-2610-C712)

#### Cut Sheet Feeders

Single Bin (ASF300-L5601)

Single Bin capable of Envelope (SF231)

Envelope Adapter (ASF300-L5621)

Double Bin Adapter (SF232 or ASF300-L5611)

Triple Bin Adapter (SF233)

### PUBLICATIONS:



Programmer's Manual for DPL24C Emulation (B-69238)

Programmer's Manual for DPL24D Emulation (B-69237)

## \*\*\*\* STANDARD FEATURES \*\*\*\*

Thank you for purchasing this high quality Fujitsu printer. You have made a wise selection. Your printer will provide years of high speed, reliable, and versatile printing.

Your printer is a multi-purpose, 24-wire dot matrix impact printer. It has been designed to satisfy most word processing, data processing and graphic printing requirements. Standard features include:

### **Seven-Color or Monochrome Printing:**

When the four-color ribbon is used in the color version printer, you get high quality character and graphic printing in seven colors.

### **Multi-emulation:**

Many kinds of emulation are available. Great capability is built into your printer. Your printer is truly an excellent multi-purpose printer.

### **Compatibility:**

The command set of your printer includes most codes of the IBM Graphics Printer, IBM Proprinter XL, Diablo 630 API printer, and Epson FX-80 printer. It also includes additional word processing, graphic and cut sheet feeder codes, in addition to Epson JX-80 color codes (accessible only in the color version).

### **Wide Variety of Control Panel Functions:**

Print Quality, Character Style, Character Spacing, Line Spacing, Language, Interface Type and Protocol are selected from the Control Panel. A 16-Character Display gives helpful messages and status information for easy operation of the printer.

### **High Quality Printing:**

Your printer has a 24-wire print head, that prints a maximum of 360 × 180 dots per square inch. The nearly straight path of continuous forms from tractor to print position reduces displacement of printed characters between each sheet of multi-part continuous forms.

### **Quiet Operation:**

Your printer uses a special low noise print mechanism as well as an acoustic cover and padding to reduce printing noise.

## **Host Interfaces:**

The standard Centronics Type Parallel or optional RS-232C Serial Interface ensures that your printer will be compatible with most host systems.

## **Font Selection of Type Fonts:**

Courier 10, Prestige Elite 12, Boldface PS, Draft and Compressed are the printer's standard fonts. Optional Font Cards provide Letter Gothic 12, Scientific 12, Orator, Boldface PS and Light Italic 12. Additional font cards are available from other vendors. Check with your Dealer for additional information on cards from Fujitsu.

## **Ease of Paper Handling:**

Automatic loading of paper simplifies printer operation. Switching from continuous form to cut sheet paper does not require removing the continuous forms from the printer. Forms tractors at the rear of the printer are easily accessible in front of the printer, facilitating paper loading of continuous forms. Optional cut sheet feeders are available in single bin models plus double bin and triple bin adapters, including envelope feed features.

## **Reliability:**

The simplified print mechanism design and proven electrical components result in high reliability and ease of maintenance if an error should occur.

## **High Speed Printing:**

Prints up to 486 characters per second – at 12 CPI and draft quality – with automatic bidirectional logic seeking printing.

## \*\*\* PURPOSE AND ORGANIZATION OF MANUAL \*\*\*

This manual is designed to help you install, set up, and use your printer. It is written for both the novice and the experienced user and organized to present information in the order that it is most likely to be required.

This manual is organized as follows:

**Quick Start** — lists the steps you should take to set up and operate the printer.

**Section 1 Setting Up Your Printer** — describes the unpacking procedure, identifies the printer's main components, and describes how to run self-test and connect your printer to a computer.

**Section 2 Getting Acquainted** — defines user functions, such as installing the ribbon cassette, paper handling procedures and the paper thickness adjustment.

**Section 3 Using the Control Panel** — provides a detailed explanation on how the control panel is used to select the printer's features. Also describes how the control panel is used to set up and operate the printer. Includes error messages and recovery methods.

**Section 4 Printer Care** — gives suggestions for keeping your printer in good operating condition and provides troubleshooting procedures. This section also includes a repacking procedure.

**Section 5 Command Sets** — lists the control codes that command the printer's functions or change the printer's operational mode through a software program. This section includes the command sets for IBM Graphics printer, IBM Proprinter XL, and Diablo 630.

**Appendices** — provide information on optional features (such as cut sheet feeders and font cards), printer specifications and interfaces. Reference tables are also included.

**Glossary of Terms** — gives an explanation or definition of unfamiliar terms.

**Index** — provides alphabetical lists of specific information for quick reference.



## \*\*\*\* APPLICATION SOFTWARE SETUP \*\*\*\*

You usually need to instruct your software what type of printer you are using. You also need to select emulation type via the Control Panel of your printer.

Don't be alarmed if your printer is missing from the list of printer options in the installation instructions for your application software.

The following tables describe possible printer selections in the printer option list of your software and appropriate emulation type selections via the Control Panel of your printer. There are two tables, one for word processing and one for business graphics and other software. In each table, selections are listed in order of preference.

### For word processing software:

Printer selection in your application software	Emulation type selection on your printer
FUJITSU DL2400 COLOR	DPL24C(*)
FUJITSU DL2400	DPL24I
FUJITSU DPL24C	DPL24C(*)
FUJITSU DotMax 24C	DPL24C(*)
FUJITSU DPL24I	DPL24I
FUJITSU DotMax 24I	DPL24I
FUJITSU DPL24D	DPL24D
FUJITSU DotMax 24D	DPL24D
DIABLO 630	DIABLO
DIABLO 1640	DIABLO
IBM Proprinter XL	IBM PRO
IBM Graphics printer	IBM GPH
EPSON JX-80	JX-80(*)(**)
EPSON FX-100	FX-80(**)
EPSON FX-80	FX-80(**)

(\*) These emulations don't appear in the emulation type selection of your printer when your printer is not color version.

(\*\*) This emulation is not fully compatible.

### For Business Graphics and other software:

Printer selection in your application software	Emulation type selection on your printer
FUJITSU DL2400 COLOR	DPL24C(*)
FUJITSU DL2400	DPL24I
FUJITSU DPL24C	DPL24C(*)
FUJITSU DotMax 24C	DPL24C(*)
FUJITSU DPL24I	DPL24I
FUJITSU DotMax 24I	DPL24I
IBM Proprinter XL	IBM PRO
IBM Graphics printer	IBM GPH
EPSON JX-80	JX-80(*)(**)
EPSON FX-100	FX-80(**)
EPSON FX-80	FX-80(**)

(\*) These emulations don't appear in the emulation type selection of your printer when your printer is not color version.

(\*\*) This emulation is not fully compatible.

## \*\*\*\* CAUTION IN OPERATION \*\*\*\*

Keep fingers, hair, ornaments etc. away from the carriage moving area.

Don't touch the print head and carriage motor, they may become hot.

Don't open the front cover during printing.

### FOR GERMAN USERS

Halten Sie Finger, Haar, Schmucke usw. fern von dem Bereich der Wagenrücklaufsbewegung.

Berühren Sie nie das Druckelement oder den Wagenrücklaufmotor, weil sie heiß sind.



.



,

## LIST OF EFFECTIVE PAGES

PAGE	REV	PAGE	REV	PAGE	REV
Cover	—	2-15	B	4-3	B
i	B	2-16	B	4-4	B
ii	B	2-17	B	4-5	B
iii	B	2-18	B	4-6	B
iv	B	2-19	B	4-7	B
v	B	Blank	—	4-8	B
vi	B	3-1	B	5-1	B
Quick Start	—	3-2	B	5-2	B
Blank	—	3-3	B	5-3	B
Q-1	B	3-4	B	5-4	B
Q-2	B	3-5	B	5-5	B
Q-3	B	3-6	B	5-6	B
Q-4	B	3-7	B	5-7	B
Q-5	B	3-8	B	5-8	B
Q-6	B	3-9	B	5-9	B
1-1	B	Blank	—	5-10	B
1-2	B	3-11	B	5-11	B
1-3	B	3-12	B	5-12	B
1-4	B	3-13	B	5-13	B
1-5	B	3-14	B	5-14	B
1-6	B	3-15	B	5-15	B
1-7	B	3-16	B	5-16	B
1-8	B	3-17	B	5-17	B
1-9	B	3-18	B	5-18	B
1-10	B	3-19	B	5-19	B
2-1	B	3-20	B	5-20	B
2-2	B	3-21	B	5-21	B
2-3	B	3-22	B	5-22	B
2-4	B	3-23	B	5-23	B
2-5	B	3-24	B	5-24	B
2-6	B	3-25	B	5-25	B
2-7	B	3-26	B	5-26	B
2-8	B	3-27	B	5-27	B
2-9	B	3-28	B	5-28	B
2-10	B	3-29	B	5-29	B
2-11	B	3-30	B	5-30	B
2-12	B	3-31	B	5-31	B
2-13	B	Blank	—	5-32	B
2-14	B	4-1	B	5-33	B
		4-2	B	5-34	B

## LIST OF EFFECTIVE PAGES

PAGE	REV	PAGE	REV
5-35	B	D-5	B
5-36	B	D-6	B
A-1	B	D-7	B
A-2	B	Blank	—
A-3	B	E-1	B
A-4	B	E-2	B
A-5	B	E-3	B
Blank	—	Blank	—
B-1	B	F-1	B
B-2	B	F-2	B
B-3	B	F-3	B
B-4	B	F-4	B
B-5	B	G-1	B
B-6	B	G-2	B
B-7	B	G-3	B
B-8	B	G-4	B
B-9	B	G-5	B
Blank	—	G-6	B
C-1	B	G-7	B
C-2	B	Blank	—
C-3	B	T-1	B
C-4	B	T-2	B
C-5	B	T-3	B
C-6	B	T-4	B
C-7	B	T-5	B
C-8	B	Blank	—
C-9	B	I-1	B
C-10	B	I-2	B
C-11	B	I-3	B
C-12	B	I-4	B
C-13	B	I-5	B
C-14	B	I-6	B
C-15	B	I-7	B
C-16	B	I-8	B
C-17	B	I-9	B
Blank	—	Blank	—
D-1	B	Cover	—
D-2	B		
D-3	B		
D-4	B		

---

# TABLE OF CONTENTS

Page

TRADEMARK ACKNOWLEDGEMENT	
PREFACE	
SUPPLIES, OPTIONS AND PUBLICATIONS	
STANDARD FEATURES	
PURPOSE AND ORGANIZATION OF MANUAL	
APPLICATION SOFTWARE SETUP	
CAUTION IN OPERATION	
QUICK START	Q-1
UNPACK PRINTER & REMOVE SHIPPING RESTRAINTS	Q-2
CHECK PRINTER	Q-2
INSTALL RIBBON CASSETTE	Q-2
TURN POWER SWITCH ON	Q-2
INSERT AND LOAD PAPER	Q-3
RUN SELF-TEST	Q-3
CONNECT THE INTERFACE CABLE	Q-4
PREPARE PRINTER FOR HOST OPERATION	Q-4
PROCEDURE FOR CHANGING PRINTER'S FEATURES	Q-6
SECTION 1 SETTING UP YOUR PRINTER	1-1
1.1 UNPACK THE PRINTER	1-1
1.2 CHECK ITEMS RECEIVED	1-2
1.3 SHIPPING RESTRAINTS	1-3
1.4 INSTALLING THE CUT-SHEET PAPER GUIDE	1-4
1.5 INSTALLATION PRECAUTIONS	1-4
1.6 PRINTER ELEMENTS	1-5
1.7 REAR VIEW OF PRINTER	1-7
1.8 ATTACH THE AC POWER CORD	1-8
1.9 RUN SELF-TEST	1-9
1.10 CONNECTING AN INTERFACE CABLE	1-10
SECTION 2 GETTING ACQUAINTED	2-1
2.1 INSTALLING A RIBBON CASSETTE	2-1
2.2 LOADING PAPER	2-5
2.2.1 Loading Continuous Forms	2-5

2.2.2	Loading Cut Sheet Paper	2-8
2.2.3	Switching Continuous Forms to Cut Sheet Paper	2-10
2.3	TEARING OFF CONTINUOUS FORMS	2-11
2.4	ADJUSTING PAPER THICKNESS	2-12
2.5	PAPER REQUIREMENTS	2-1 <sup>A</sup>
SECTION 3 USING THE CONTROL PANEL		
3.1	CONTROL PANEL LAYOUT	3-1
3.2	CENTER SECTION (NORMAL MODE)	3-3
3.3	LOWER SECTION (ALTERNATE MODE)	3-5
3.4	UPPER SECTION (SETUP MODE)	3-6
3.4.1	Setup Mode Structure	3-7
3.5	FUNCTION LEVEL	3-11
3.6	ITEM LEVEL	3-12
3.7	MENU FUNCTION SELECTIONS	3-12
3.7.1	SEL MENU Function	3-12
3.7.2	MENU1 (MENU2) Function	3-13
3.8	HARDWARE FUNCTION SELECTIONS	3-18
3.9	SAVE FUNCTION	3-22
3.10	LIST FUNCTION	3-22
3.11	DEFAULT FUNCTION	3-24
3.12	SELF TEST FUNCTION	3-
3.13	HEX DUMP FUNCTION	3-28
3.14	VERTICAL ALIGNMENT FUNCTION	3-27
3.15	TOP OF FORM ADJUSTMENT FUNCTION	3-28
3.16	ERROR MESSAGES	3-29
SECTION 4 PRINTER CARE		
4.1	PRINTER INITIALIZATION	4-1
4.2	REMOVING A PAPER JAM	4-2
4.3	REPLACING FUSE	4-3
4.4	CLEANING AND LUBRICATING	4-5
4.5	BASIC TROUBLESHOOTING	4-6
4.6	REPACKING YOUR PRINTER	4-8
SECTION 5 COMMAND SETS		
5.1	OUTLINE	5-1
5.2	DPL24C EMULATION	5
5.3	DPL24D EMULATION	5-
5.4	IBM-PRO EMULATION	5-28



APPENDIX A CUT SHEET FEEDERS .....	A-1
APPENDIX B RESIDENT AND CARD FONTS .....	B-1
APPENDIX C INTERFACE SPECIFICATIONS .....	C-1
C.1 PARALLEL INTERFACE .....	C-1
2 SERIAL INTERFACE .....	C-7
APPENDIX D EXCHANGING RIBBON SUBCASSETTES .....	D-1
APPENDIX E PRINTER SPECIFICATIONS .....	E-1
APPENDIX F CHARACTER SET TABLES .....	F-1
APPENDIX G CODE CONVERSION TABLES .....	G-1
GLOSSARY OF TERMS .....	T-1
INDEX .....	I-1

## LIST OF ILLUSTRATIONS

	Page
Figure 1-1	Items received . . . . . 1-2
Figure 1-2	Shipping restraints . . . . . 1
Figure 1-3	Installing the paper guide . . . . . 1
Figure 1-4	Printer elements . . . . . 1-5
Figure 1-5	Rear view of printer . . . . . 1-7
Figure 1-6	AC power cord . . . . . 1-8
Figure 1-7	Self-test print pattern . . . . . 1-9
Figure 1-8	Interface connectors . . . . . 1-10
Figure 2-1	Ribbon cassette installation (1 of 4) . . . . . 2-2
Figure 2-2	Ribbon cassette installation (2 of 4) . . . . . 2-2
Figure 2-3	Ribbon cassette installation (3 of 4) . . . . . 2-3
Figure 2-4	Ribbon cassette installation (4 of 4) . . . . . 2-3
Figure 2-5	Ribbon path . . . . . 2-4
Figure 2-6	Loading continuous forms (1 of 3) . . . . . 2-6
Figure 2-7	Loading continuous forms (2 of 3) . . . . . 2-6
Figure 2-8	Loading continuous forms (3 of 3) . . . . . 2-7
Figure 2-9	Loading cut-sheet paper (1 of 3) . . . . . 2-9
Figure 2-10	Loading cut-sheet paper (2 of 3) . . . . . 2
Figure 2-11	Loading cut-sheet paper (3 of 3) . . . . . 2-10
Figure 2-12	Tearing off continuous forms . . . . . 2-12
Figure 2-13	Paper thickness lever . . . . . 2-13
Figure 2-14	Print area on continuous forms . . . . . 2-16
Figure 2-15	Print area on cut sheet paper . . . . . 2-17
Figure 3-1	Control panel layout . . . . . 3-1
Figure 3-2	Display transition in setup mode . . . . . 3-7
Figure 3-3	Control panel flowchart . . . . . 3-9
Figure 3-4	List function . . . . . 3-23
Figure 3-5	Self-test function . . . . . 3-25
Figure 3-6	Hex-dump function . . . . . 3-26
Figure 3-7	Vertical alignment function . . . . . 3-28

Figure 4-1	Replacing the fuse	4-3
Figure A-1	Preparing the printer	A-2
Figure A-2	Mounting the cut sheet feeder	A-2
Figure A-3	Connecting the cut sheet feeder cable	A-3
Figure B-1	Inserting the font card	B-7
Figure B-2	Font card label	B-9
Figure C-1	Parallel interface output circuit	C-1
Figure C-2	Parallel interface input circuit	C-2
Figure C-3	Parallel interface connector	C-2
Figure C-4	Data transmission timing	C-6
Figure C-5	Serial interface input circuit	C-8
Figure C-6	Serial interface output circuit	C-8
Figure C-7	Serial interface connector	C-9
Figure C-8	Serial data format	C-11
Figure D-1	Four-color ribbon subcassette	D-1
Figure D-2	Replacing the four-color ribbon subcassette (1 of 6)	D-2
Figure D-3	Replacing the four-color ribbon subcassette (2 of 6)	D-2
Figure D-4	Replacing the four-color ribbon subcassette (3 of 6)	D-3
Figure D-5	Replacing the four-color ribbon subcassette (4 of 6)	D-3
Figure D-6	Replacing the four-color ribbon subcassette (5 of 6)	D-4
Figure D-7	Replacing the four-color ribbon subcassette (6 of 6)	D-4
Figure D-8	Replacing the black ribbon subcassette (1 of 6)	D-5
Figure D-9	Replacing the black ribbon subcassette (2 of 6)	D-5
Figure D-10	Replacing the black ribbon subcassette (3 of 6)	D-6
Figure D-11	Replacing the black ribbon subcassette (4 of 6)	D-6
Figure D-12	Replacing the black ribbon subcassette (5 of 6)	D-7
Figure D-13	Replacing the black ribbon subcassette (6 of 6)	D-7

## LIST OF TABLES

		Page
Table 2-1	Paper thickness lever adjustment .....	2-12
Table 2-2	Paper requirements .....	2
Table 3-1	Function chart .....	3-11
Table 3-2	Menu function selectable options .....	3-14
Table 3-3	Hardware function selectable options .....	3-19
Table 3-4	Operational error messages .....	3-29
Table 3-5	Paper handling error messages .....	3-30
Table 3-6	Serial interface error messages .....	3-30
Table 3-7	Memory error messages .....	3-31
Table 3-8	Downloading error message .....	3-31
Table 3-9	Mechanical error messages .....	3-31
Table 4-1	Troubleshooting hints .....	4-6
Table C-1	Parallel interface signals .....	C-3
Table C-2	Serial interface signals .....	C-10

## Quick Start



## Section 1 Setting up Your Printer

## Section 2 Getting Acquainted

## Section 3 Using the Control Panel

## Section 4 Printer Care

## Section 5 Command Sets



## Appendixes, Glossary & Index

Quick  
Start

Setting  
Up

Getting  
Acquainted

Control  
Panel

Printer  
Care

Command  
Sets

Appendixes  
Glossary & Index



# QUICK START

This Quick Start section is intended for users who want to operate their printer shortly after taking it out of the shipping carton. Refer to this Quick Start Chart and the following paragraphs.

## QUICK START CHART

What You Do:	What You Check:	Refer To:
Unpack printer	All received items	Page 1-1
Open front cover & remove shipping restraints	Print head carriage for smooth side to side movement	Page 1-3
Prepare printer for operation	Review Installation Precautions	Page 1-4
Install ribbon cassette	Ribbon path between print head and ribbon mask	Carton or Page 2-1
Install paper guide		Page 1-4
Attach AC cord	Ensure voltage is OK	Page 1-7
Insert paper	Paper width/position	Page 2-5
Run Self-Test	Printer performance	Page 1-8
Connect interface cable	Type of interface & cable connection	Page 1-10

Connect the printer to your host computer and check the printer's performance.

Refer to your computer documentation and Section 3 for printer set up information. Refer to Section 4 for Troubleshooting hints.

## **UNPACK PRINTER & REMOVE SHIPPING RESTRAINTS**

Refer to the instructions on the shipping carton.

### **CHECK PRINTER**

Print head carriage – should move smoothly from side to side.

Ribbon feed shaft – rotates when the print head carriage is moved.

Paper bail lever – lifts roller off the platen.

Paper path lever – sets continuous form or cut sheet paper mode.

Forms tractors – rotate freely when the paper path lever is set to the front of the printer.

Paper thickness lever (manual version only) - sets gap between the platen and print head.

### **INSTALL RIBBON CASSETTE**

Refer to instructions on the ribbon carton, or page 2-1.

### **TURN POWER SWITCH ON**

Check that the control panel display briefly shows "INTERNAL TEST" and "INTERNAL TEST OK". The Display will then show "ON-LINE READY".

A "PAPER OUT ERROR" message is shown if the paper path lever is towards the front of the printer.



## INSERT AND LOAD PAPER

Ensure that the paper path lever is set towards the front of the printer for continuous form and towards the rear of the printer for cut-sheet paper.

Load paper by pulling the paper bail lever towards the front of the printer, and then hold the ALT/(RESET) button, on the control panel, down while pressing the LOAD/(FF) button.

Return the paper bail lever to its original position after the paper is loaded.

Set the paper thickness lever to the proper position when your printer is not an automatic version. (Page 2-11)

## RUN SELF-TEST

Self-test prints a test pattern to check the printer's performance.

See Section 4 for basic troubleshooting hints if a fault should appear.

### Starting Self-Test

Start self-test by turning power on while holding the FUNCTION/(FF) button down.

**Self-test may also be started as follows:**

1. Hold the ALT/(RESET) button down while pressing the SETUP/(ONLINE) button. The control panel display flashes "SETUP MODE", then it shows "FUNCTN:SEL.MENU".
2. Press the FUNCTION/(FF) button until the display advances to "FUNCTN:SELF-TST".

Each press of this button advances the display through one of its ten functions: SEL.MENU, MENU1 or 2, HARDWARE, SAVE, LIST, EFAULT, SELF-TST, HEX-DUMP, V-ALNMNT, and TOF-ADJ.

3. Start printing the self-test print pattern by pressing the SELECT/(RESET) button.

The display changes to "SELF TEST PRINT".

## Stopping Self-Test

Halt self-test by pressing the ITEM/(LF) or SELECT/(RESET) button. The display changes to "SELF TEST PAUSE".

Restart self-test, by pressing the SELECT/(RESET) button again.

Stop the self-test by turning power off, or by pressing the EXIT/(ONLINE) button; printing stops and the display changes to "ON-LINE:READY".

## CONNECT THE INTERFACE CABLE

Be sure that you are using the correct interface cable.

Parallel Interface Cable – connector is a 36-pin shield type plug, AMP DDK 57FE-30360 or equivalent (see [Appendix C](#)).

RS-232-C Serial Interface Cable – connector is a 25-pin plug, Canon DB-25 or equivalent (see [Appendix C](#)).

Consult with your dealer for any modifications that may be required for your cable pin assignments - depending upon your computer's maker and model number.

## PREPARE PRINTER FOR HOST OPERATION

If you are using the parallel interface, you may only have to choose an equivalent printer type from the list of printer options given in the software package installation instructions. With some exceptions, this printer emulates a Fujitsu DPL24I (DotMax 24I), IBM Graphics printer, IBM Proprinter XL or Diablo 630 API printer; with the color version it emulates an Epson JX-80 or Fujitsu DPL24C (DotMax 24C).

To satisfy the requirements of your documentation, host computer or software application, you may need to change some selections of the printer's features (MENU and HARDWARE). For MENU selection: two kinds of default settings are provided as MENU1 and MENU2. A procedure for changing these selections is given on page Q-6 (refer to Section 3 for a complete explanation of the control panel).

The following shows factory settings of MENU1 and MENU2.

FUNCTION: SEL.MENU  
SELECT :MENU1

FUNCTION:	MENU1	MENU2
QUALITY:	LETTER	LETTER
FONT :	COUR 10	COUR 10
CHAR SP:	10 CPI	10 CPI
LINE SP:	6 LPI	6 LPI
EMULATE:	DPL24C	DPL24C
ATTRIB :	NONE	NONE
PAGE LG:	11.0 IN	11.0 IN
COLOR :	BLACK	BLACK
LFT-END:	1 COLM	1 COLM
TOP-MRG:	1 LINE	1 LINE
LANGUGE:	USA	USA
CHR-SET:	SET 2	SET 2
GRPH-LF:	IBM-GPH	IBM-GPH
PRF-SKP:	NO-SKIP	NO-SKIP
WIDTH :	13.6 IN	13.6 IN
ZEROFNT:	NO-SLSH	NO-SLSH
DC3-CDE:	ENABLE	ENABLE
CR-CODE:	CR ONLY	CR ONLY
LF-CODE:	LF & CR	LF & CR
RGHTEND:	WRAP	WRAP

FUNCTION: HARDWARE

SPEED :NORMAL  
PPR-OUT: CNTONLY  
PRT-DIR: BI-DIR  
BUZZER :ON  
WORD-LG: 8 BIT  
BUFFER : 8KBYTE  
FEEDER :NONE  
INTRFCE: SERIAL  
FORMAT :8NONE 1  
BAUD-RT: 9600  
PROTOCL: XON/XOF  
DUPLEX :FULL

These items don't appear  
when "PARALEL" is  
selected for "INTRFCE".

## PROCEDURE FOR CHANGING PRINTER'S FEATURES

Refer to Section 3 for additional details.

1. Hold the ALT/(RESET) button down while pressing the SETUP/(ONLINE) button. The control panel display flashes "SETUP MODE", then shows "FUNCTN:SEL.MENU".
2. Press the FUNCTION/(FF) button until MENU1 (2) or HARDWARE is displayed. Each time you press this button the display is advanced to its next function. There are ten functions: SEL.MENU, MENU1 or 2, HARDWARE, SAVE, LIST, DEFAULT, SELF-TST, HEX-DUMP, V-ALNMNT, and TOF-ADJ.
3. Press the ITEM/(LF) button to enter the item selection routine, when MENU1 (2), HARDWARE or TOF-ADJ is displayed.
4. Press the ITEM/(LF) button until the desired item is displayed. If you hold this button down, each item will be displayed with a brief interval between each display.
5. Change a currently selected option by pressing the SELECT/(RESET) button until the option you wish to select is displayed, then press the ITEM/(LF) button to return to the item selection level (the last displayed option is automatically selected).
6. Repeat steps 2, 3 and 4 as required to set the necessary options. Go to step 7 after selecting all necessary options.
7. To save your selections in nonvolatile memory, press the FUNCTION/(FF) button until the display advances to show "FUNCTN:SAVE", and then press the SELECT/(RESET) button. The display flashes "SAVING NOW!!" then shows "FUNCTN:SAVE".

**NOTE:**

If you do not perform this operation, your selections will be lost when power is turned off. (temporary setting)

8. Press the EXIT/(ONLINE) button to place the printer online.

The display will show "ON LINE:READY".

# SECTION 1

## SETTING UP YOUR PRINTER

### 1.1 UNPACK THE PRINTER

Printer unpacking instructions are given on the shipping carton and summarized below. Refer to the drawing on the shipping carton.

Inspect the shipping carton and packing material as you unpack your printer.

Unlatch and remove the plastic handles on the side of the shipping carton.

Open the flaps (of the carton) and slide the accessory tray out of the carton.

Remove the ribbon cassette, platen knobs, cut sheet paper guide, AC power cord, and user's manual from the accessory tray.

Slide the printer out of the carton.

Place the printer on a sturdy desk or table, near its operating location.

Remove the printer and accessories from their protective shipping bags.

Remove the tape from the printer's top cover and raise the cover.

Identify major printer elements (see Page 1-5).

If any shipping damage is notified, immediately notify your dealer/distributor or shipping agent

Open the shipping carton and all packing materials for storage or reshipment of your printer.

## 1.2 CHECK ITEMS RECEIVED

Ensure that you have the items shown below:

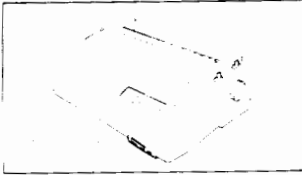

### Printer

Platen knobs are shipped in the accessory tray

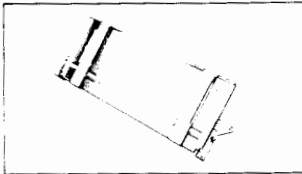

### Cut sheet paper guide

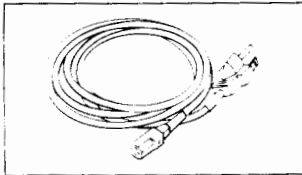

### Power cord

100-120 VAC – 3 prongs (USA)  
220-240 VAC – 2 prongs (Europe)

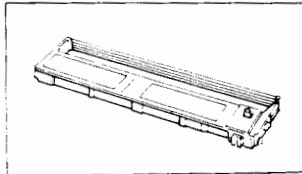

### Ribbon cassette

Black if monochrome model  
Four-color if color model

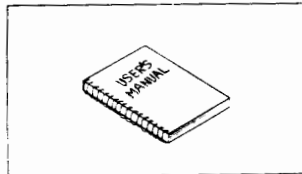

### User's Manual

Figure 1-1 Items received

## 1.3 SHIPPING RESTRAINTS

Remove the tape from the top of the printer and open the front cover.

Remove the tape and foam shipping restraints from the top and bottom of the ribbon platform.

Pull out the yellow print head shipping restraint and remove the two ties from the left and right sides of the paper bail.

Store all shipping restraints for reshipment of your printer.

Setting Up

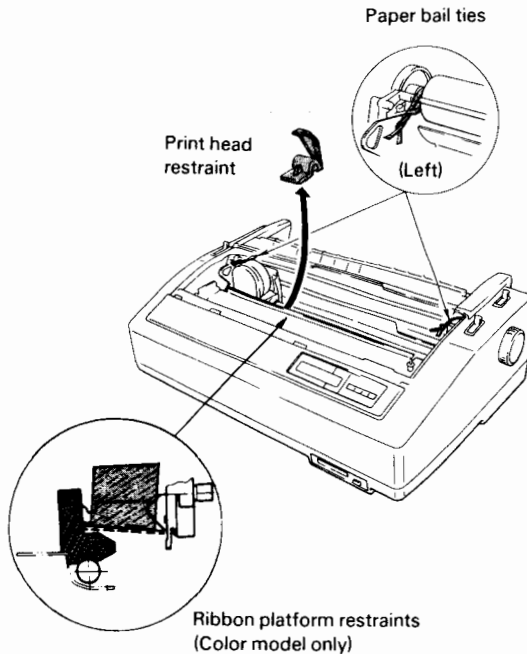

Figure 1-2 Shipping restraints

## 1.4 INSTALLING THE CUT-SHEET PAPER GUIDE

The cut sheet paper guide enables smooth feeding of continuous form paper as well as cut-sheet paper. You had better mount the cut sheet paper guide on your printer before operating the printer.

Mount the guide on the rear cover of the printer case, snapping its mounting arms into place (Figure 1-3).

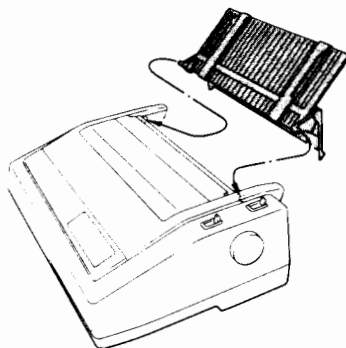

Figure 1-3 Installing the paper guide

## 1.5 INSTALLATION PRECAUTIONS

Install your printer on a level surface to prevent excessive vibration.

Do not install your printer in direct sunlight or near a heater where it may become overheated.

Do not block ventilation around your printer, which could also cause overheating.

Do not operate your printer in a humid or dusty environment, which may allow contaminants to enter the printer.

Do not place obstacles near the platen knobs which could prevent the platen from turning and cause a paper misfeed.



Use only proper AC voltage and a power outlet that is not shared with heavy industrial equipment that may generate electrical noise.

Select a location within the length of your interface cable (generally less than 10 feet) and convenient to an AC power outlet.

The location should allow easy access to:

Operator's control panel – To allow set up and operation of the printer.

Printer's front and rear covers – For access into the printer for ribbon changing, paper thickness lever control, and continuous form tractor handling.

Rear of printer – For access to the printer's interface cable and power cord.

## 1.6 PRINTER ELEMENTS

The location of major printer elements are shown below and described in the following paragraphs:

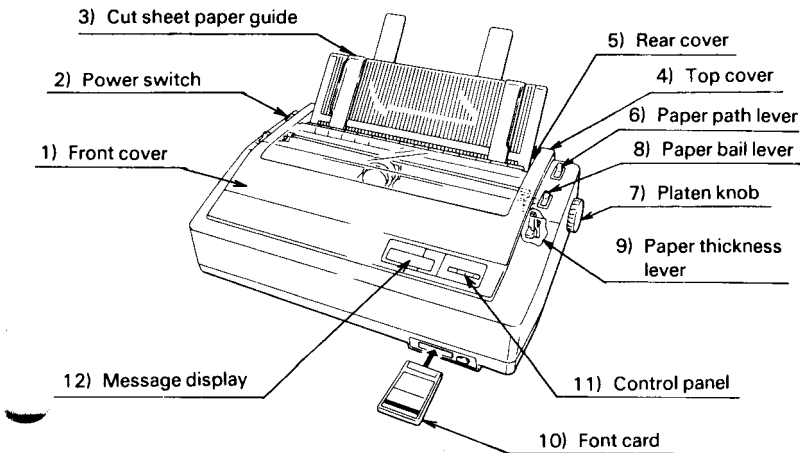
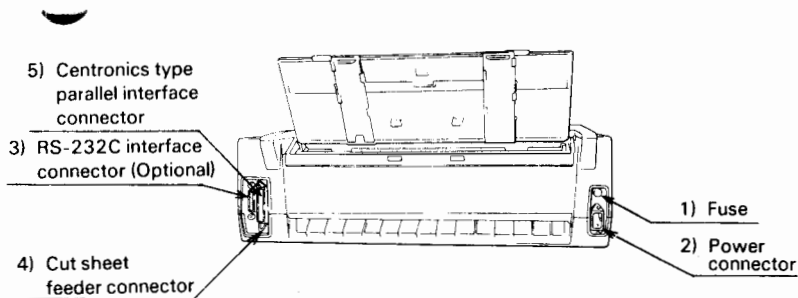

Figure 1-4 Printer elements

- 1) Front cover – Open for access into printer for ribbon installation, paper thickness adjustments, and other user oriented activities in the carriage area. Stops printing if it is opened during print operation.
- 2) Power switch – Initializes the printer and illuminates the power lamp when turned on. Removes power from the printer when turned off.
- 3) Cut-sheet paper guide – Use to guide single cut sheet paper and continuous form into and out of the printer.
- 4) Top cover – Remove for installation of the optional cut sheet feeder.
- 5) Rear cover – Open for access to the continuous form tractor mechanisms.
- 6) Paper path lever – Set to the back of the printer for friction feed (cut sheet paper); set to the front of the printer for tractor feed (continuous form). Friction feeding of the cut sheet paper path always functions regardless of the setting.
- 7) Platen knob – Turn to manually feed paper.
- 8) Paper bail lever – Controls paper bail shaft that holds the paper against the platen.
- 9) Paper thickness lever (manual version only) – Varies the gap between the print head and platen to accommodate different paper thickness or multiple forms.
- 10) Font card – Optional font cards may be installed into the printer.
- 11) Control panel – see Section 3 - Used to control paper, select printer options, and control printing.
- 12) Message display – 16-character liquid crystal display that provides operational and error messages.

## 1.7 REAR VIEW OF PRINTER

The location of printer elements on the rear of the printer is shown in the following drawing:



**Figure 1-5 Rear view of printer**

- 1) Fuse – Protects electrical components from excessive current. May be checked or replaced by an operator.
- 2) Power connector – The AC power cord connects to the printer with this connector.
- 3) RS-232C interface connector (optional) – The host computer's serial port connects to the printer with this connector.
- 4) Cut sheet feeder connector – Provides power and control signals to the optional sheet feeder.
- 5) Centronics type parallel interface connector – The host computer's parallel port connects to the printer with this connector.

## 1.8 ATTACH THE AC POWER CORD

Ensure that the power outlet matches the power cord plug with the ground lug properly grounded.

Connect the power cord to the printer then to the power outlet, as shown below.

When you prepare the power cord, its length must be 3 m or less.

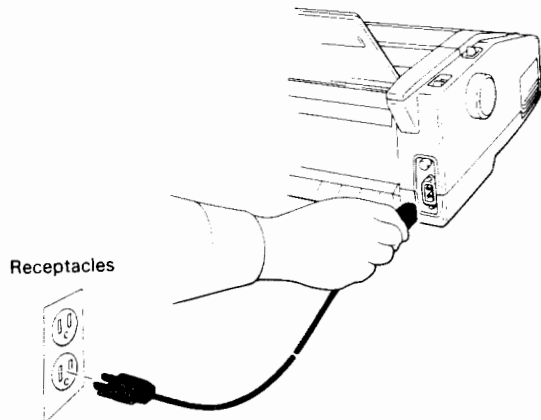

Figure 1-6 AC power cord

Turn the power switch to the on position. When power is turned on, your printer will:

Light the green POWER lamp (on the control panel)

Move the print head to its home position

With the paper path lever set to the rear of the printer, the display briefly shows "INTERNAL TEST", "INTERNAL TEST OK", then "ON-LINE:READY".

# 1.9 RUN SELF-TEST

Install a ribbon (refer to paragraph 2.1) and load paper (refer to paragraph 2.2 or 2.3) before starting the self-test.

If you plan to run self-test, we recommend that you use continuous forms more than 10 inches wide. Self-test prints 80 characters per print line and if printing occurs without the paper, the print head and platen may be damaged.

Setting Up

Start the self-test by holding the FUNCTION/(FF) button down while turning power on. Refer to Section 3 and page Q-3 for additional information.

```

=== SELF TEST PRINTING ===
ACTION                                BUTTON
Exit to normal mode                   < ONLINE >
Return to main Function menu         < F F >
Pause printing                        < L F >
Resume printing                       < RESET >

1 Software Revision: IC1A , IC2A (D202)

2 Repeat Printing

```

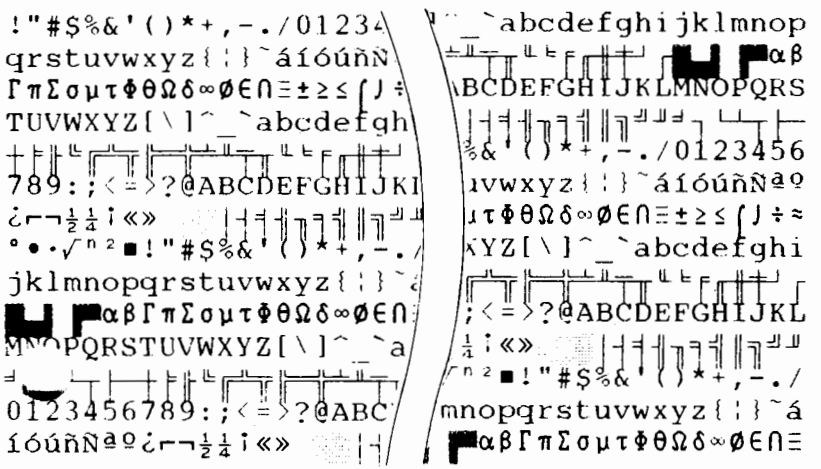

Figure 1-7 Self-test print pattern

## 1.10 CONNECTING AN INTERFACE CABLE

The printer communicates with the host computer through a Centronics type parallel interface or optional RS-232C serial interface. Refer to your computer documentation for interface information on your computer.

Refer to Figure 1-8 for the location of the interface connectors.

See Appendix C for interface hardware configuration.

The interface cable is not supplied with the printer, but available from most dealers, independent cable manufacturers and others.

### CAUTION:

Make sure the printer and computer are turned off before connecting the interface cable.

Connect one end of the cable to your printer and the other end to your computer.

Lock a parallel interface connector to your printer by snapping the cable latches inward.

Lock a serial interface connector to the printer by tightening the cable connector screws.

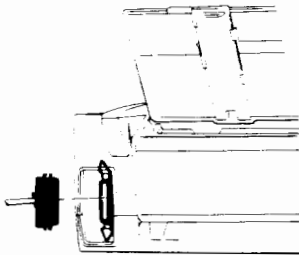

Parallel (Centronics) Connection

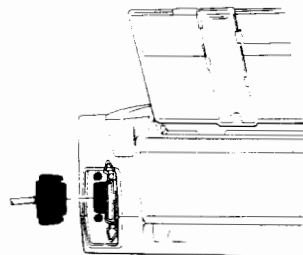

Serial (RS-232C) Connection

**Figure 1-8 Interface connectors**

## SECTION 2

# GETTING ACQUAINTED

## 2.1 INSTALLING A RIBBON CASSETTE

This procedure is used for installing a four-color or black ribbon cassette. You will also find ribbon installation/removal instructions on each ribbon cassette carton.

Your printer is shipped with a ribbon cassette for the print mechanism. There are two types of print mechanism: a color print unit and monochromatic print unit. A black ribbon cassette can be used on the color print unit, but a color ribbon cannot be used on the monochromatic print unit.

Getting  
Acquainted

Open the front cover.

2. If power is off, move the print head to the center of the print line.
3. Pull the transportation tab out of the ribbon cassette (Figure 2-1).

Handle the ribbon cassette carefully, to prevent the ribbon from twisting, after removing the transportation tab.

4. Grasp the ribbon release, between your thumb and forefinger, and push in the direction of the arrows to close the ribbon drive rollers (Figure 2-1).

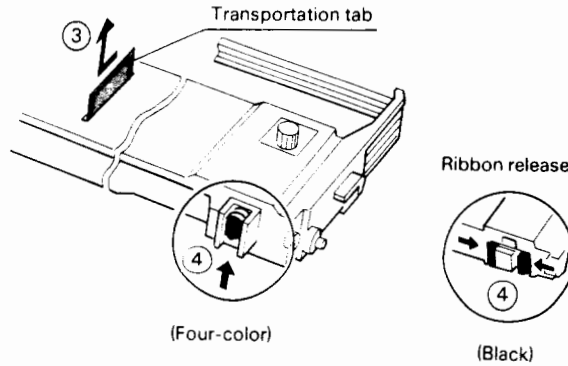

**Figure 2-1 Ribbon cassette installation (1 of 4)**

5. Rotate the ribbon feed knob in a clockwise direction to tighten the ribbon (Figure 2-2).

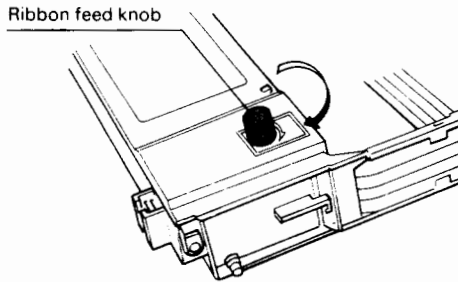

**Figure 2-2 Ribbon cassette installation (2 of 4)**

6. Pull the paper thickness lever towards you, to position D (Figure 2-3). This step is unnecessary for the printer with the automatic paper thickness detection feature.
7. Push down on the front (your side) of the ribbon cassette support frame to be sure it is in its up position (Figure 2-3) for the color version.



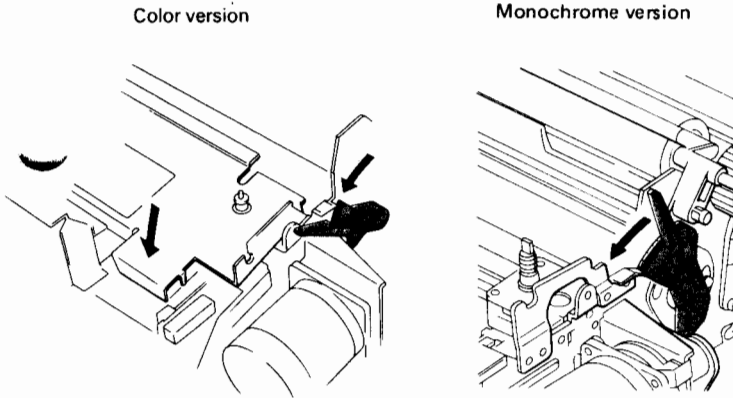

**Figure 2-3 Ribbon cassette installation (3 of 4)**

8. Insert the ribbon cassette's left and right mounting pins into the guide notches of the side frame. Push the cassette forward, while pivoting it on the mounting pins, then snap it into place (Figure 2-4).

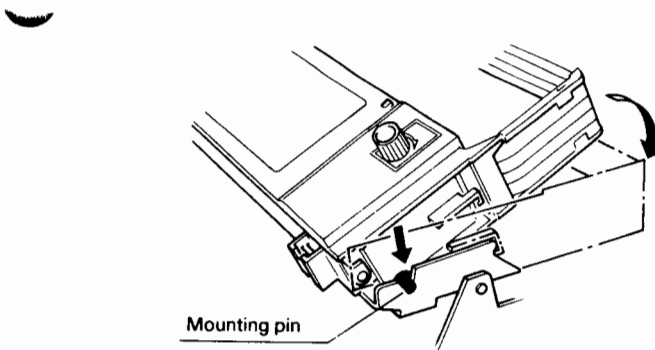

**Figure 2-4 Ribbon cassette installation (4 of 4)**

9. Guide the ribbon through the ribbon guide shafts on the print head (Figure 2-5).

If power is off, move the print head from side to side, to ensure that the ribbon is correctly seated.

Getting Acquainted

**NOTE:**

Do not allow the ribbon to touch the print head guide shaft which may cause it to be stained with grease.

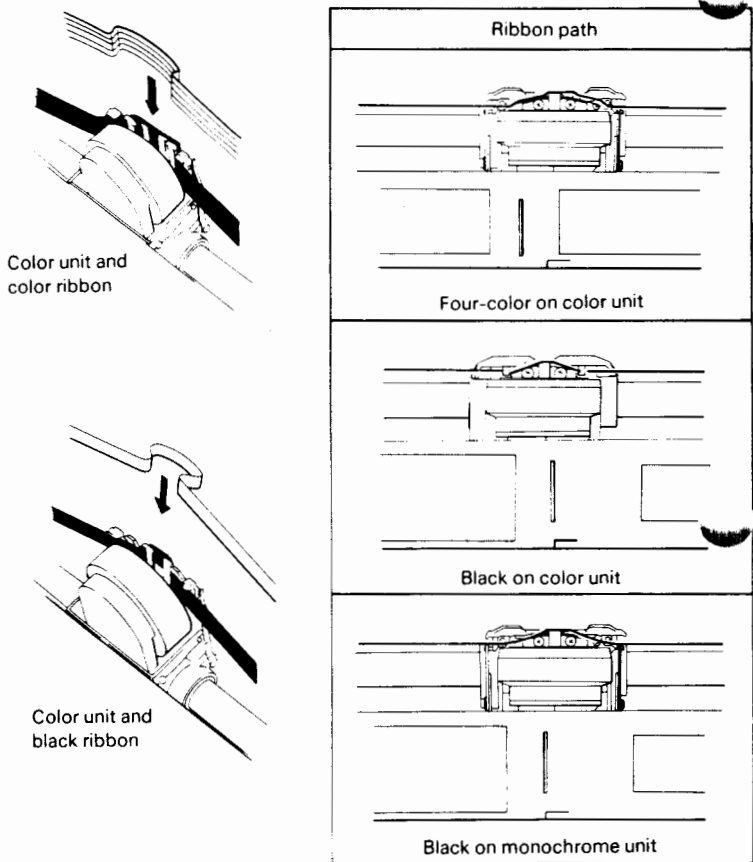

**Figure 2-5 Ribbon path**

10. Set the paper thickness lever to the correct position (refer to paragraph 2.4); tighten the ribbon again (see step 5); and close front cover.

## Replacing the ribbon cassette

Remove the ribbon cassette as follows and install a new ribbon cassette as shown in the above.

1. pen the front cover.
2. Move the print head to the center.
3. Set the paper thickness lever to position D (manual version only).
4. Lift the ribbon cassette toward you to release the lock and take the ribbon cassette out.

## 2.2 LOADING PAPER

### NOTE:

The leading edge of paper must not be curled or damaged; it may cause a paper jam.

 When loading paper for the self-test, use paper that is at least 10 inches wide to prevent printing on the platen.

See Appendix A when loading paper with an optional cut sheet feeder installed.

### 2.2.1 Loading Continuous Forms

Continuous forms have holes on the left and right margins. This section describes how to fit these holes into the forms tractors and load the forms into the printer.

1. Remove any paper that is loaded in the printer.

 Set the paper path lever towards the front of the printer.

3. Lift the cut sheet paper guide and pull it down towards you then open and hook the rear cover onto the guide, to expose the forms tractors.
4. Set the paper thickness lever to position D (manual version only)

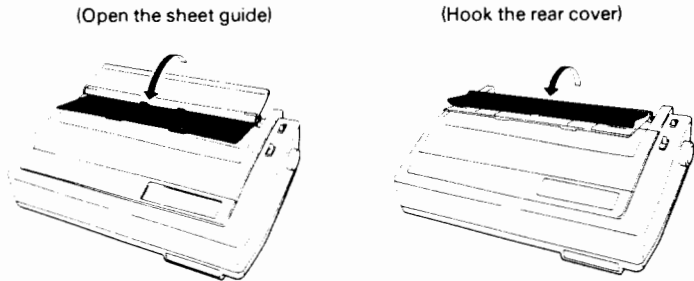

**Figure 2-6 Loading continuous forms (1 of 3)**

5. To adjust the tractors to the width of the form, push the tractor lock levers downward.
6. Open the left and right forms tractor door plates.

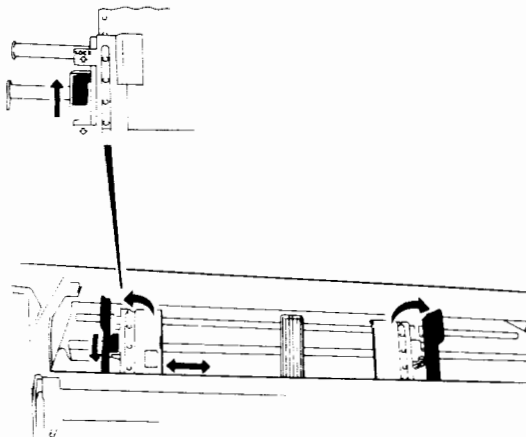

**Figure 2-7 Loading continuous forms (2 of 3)**

7. Guide the form under the top cover (from the rear of the printer) into the forms tractors.
8. Fit the form's feed holes onto the right and left forms tractors pins.
9. Close the forms tractor door plates and adjust the position of the form.
10. Move the forms tractors until the form is stretched taut between the tractors. Pull the tractor lock levers upward to lock the tractors.
11. Adjust the paper thickness lever (manual version only).
12. Close the rear cover and push down the cut sheet paper guide to the rear.
13. Ensure power is turned on and pull the paper bail lever towards the front of the printer.
14. While holding the ALT/(RESET) button down, press the LOAD/(FF) button on the control panel, and the form will advance to the first print position.
15. Return the paper bail lever to its closed position.
16. Arrange the paper as shown in Figure 2-8 to ensure smooth feeding and folding of paper.

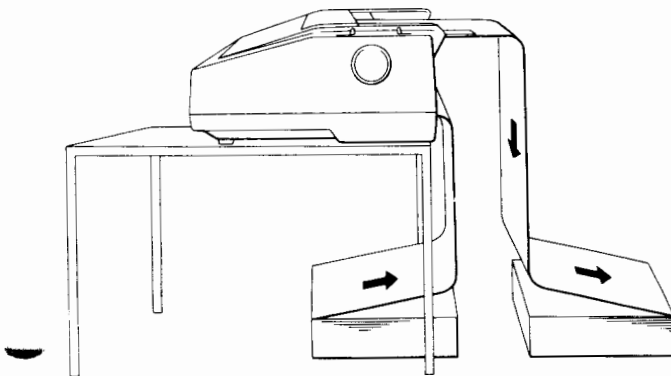

**Figure 2-8 Loading continuous forms (3 of 3)**

17. To adjust the print position, use micro LF mode. See paragraph 3.3 for micro LF mode.

**NOTE:**

If you use the platen knob to feed the paper backward when adjusting the print position, the printing may be placed out of position due to mechanical play. Adjust the print position using forward micro feed at least 2 or 3 mm.



## 2.2.2 Loading Cut Sheet Paper

If continuous forms are loaded, pull the paper bail lever towards the front of the printer. Tear the forms at the perforation nearest the platen on the print head side.

Retract the forms from the printer by holding down the ALT/(RESET) button and then pressing the LOAD/(FF) button on the control panel.

Continue holding the ALT/(RESET) button down and pressing the LOAD/(FF) switch until the forms are fully retracted and the display shows "PAPER OUT ERROR".



There is no need to remove the paper from the tractors, it will not affect cut sheet feeding.

Refer to Appendix A if using an optional cut sheet feeder.

1. Ensure power is on.
2. Set the paper path lever towards the rear of the printer.
3. Stand the cut sheet paper guide and adjust the right and left stoppers to the width of the paper.



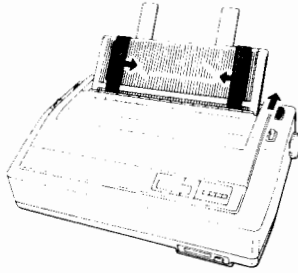

**Figure 2-9 Loading cut-sheet paper (1 of 3)**

4. Completely insert the paper between the cut sheet paper guide and the platen.

**NOTE:**

Make sure that the paper rests against the feed belts.

5. Pull the paper bail lever towards the front of the printer.
6. While holding the ALT/(RESET) button down, press the LOAD/(FF) button. The paper will advance to the first print line (about one-inch below the top of the paper).

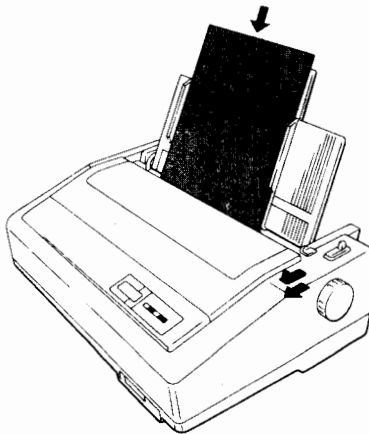

**Figure 2-10 Loading cut-sheet paper (2 of 3)**

## 7. Return the paper bail lever to its closed position.

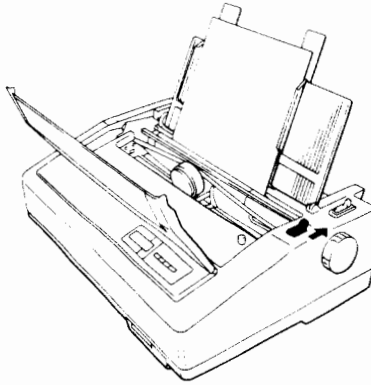

**Figure 2-11 Loading cut-sheet paper (3 of 3)**

To adjust the print position, use micro LF mode. See paragraph 3.3 for micro LF mode.

**NOTE:**

If you use the platen knob to feed the paper backward when adjusting the print position, the printing may be placed out of position due to mechanical play. Adjust the print position using forward micro feed at least 2 or 3 mm.

### 2.2.3 Switching Continuous Forms to Cut Sheet Paper

When continuous forms are in your printer, you do not need to remove the forms from your printer; you can change the forms to cut sheet paper as follows:

1. Ensure the paper path lever is in the forward position.
2. Tear off the forms at the perforations nearest the platen on the  head side.
3. Pull the paper bail and press the LOAD/(FF) button with the ALT/(RESET) button pressed (the forms are unloaded).



4. Push the paper path lever to the rear position.
5. Insert cut-sheet paper behind the platen.
6. Press the LOAD/(FF) button with the ALT/(RESET) button pressed (the cut-sheet paper is loaded).
7. Restore the paper bail.

**NOTE:**

The continuous forms remain on the forms tractors but do not move as long as the paper path lever is in the rear position.

When you have finished printing your cut sheet paper, change it to continuous forms by merely pulling the bail lever, placing the paper path lever to its forward position and pressing the LOAD/(FF) button with the ALT/(RESET) button pressed. The continuous forms will be loaded.

Getting  
Acquainted

## 2.3 TEARING OFF CONTINUOUS PAPER

This printer has the "tear bar" on the top cover. It enables you to tear off continuous forms along horizontal perforation just by pressing the ONLINE and FF buttons simultaneously. Paper is controlled so that the bottom edge perforation of the last printed page can be under the tear bar and the top-of-form position of the next first page be under the print head after tearing. This function saves paper which is liable to be wasted as a white page when tearing off continuous forms.

1. Press the ONLINE and FF buttons when the form is on the top of form position. The display changes to "TEAR PAPER OFF!" and the perforation of the form advances to the "tear bar" position.
2. Tear the printed form off.

Press the RESET button. The display returns to the previous message and the form moves back to the top of form position.

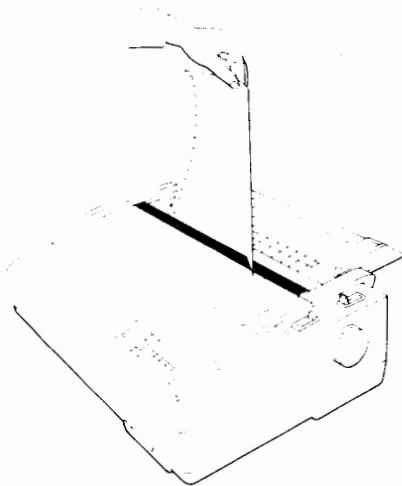

**Figure 2-12** Tearing off continuous forms

## **2.4 ADJUSTING PAPER THICKNESS**

Two versions are available for paper thickness control. One has a sensor which automatically detects paper thickness and a motor which adjusts the gap between head and paper. The other has a paper thickness lever to be operated manually. When your printer is automatic version, you do not need to adjust paper thickness.

When the paper thickness lever is moved one notch, the print head moves about 0.05mm, therefore each notch of movement corresponds to about one sheet of 10-pound paper.

Adjust the gap, between the print head and platen, for paper thickness variations as described below:

1. Open the front cover and locate the paper thickness lever (at the side of the printer).
2. Select an appropriate notch from Table 2-1.

**Table 2-1 Paper thickness lever adjustment**

Paper thickness	Notch position
Single part	1 or 2
Two parts	2
Three parts	3
Four parts	4
Five parts	5
Six parts	A
Envelope*	Near D
Ribbon Exchange	D

\* Avoid envelopes thicker than 0.5mm.

Getting Acquainted

Too narrow a gap may cause:

Paper damage at left or right margin.

accurate line feeding.

Ribbon to become loose, or come off its guides, during printing.

Too wide a gap may cause:

Light printing or characters to be missed.

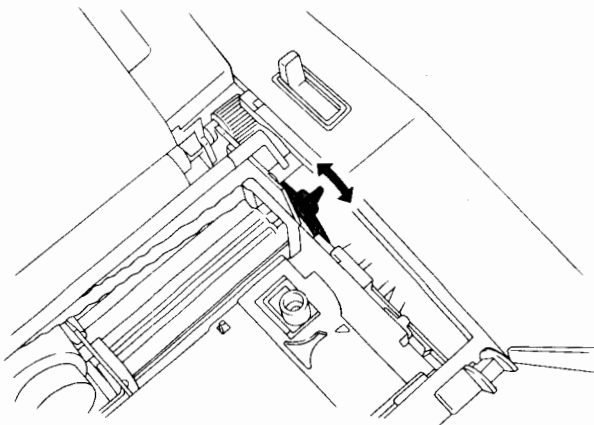

**Figure 2-13 Paper thickness lever**

## 2.5 PAPER REQUIREMENTS

You can use letter paper, typewriter paper, copy paper, business forms, and other types of stock forms which will be common at your home or office. However, if you want to use unusual paper, such as envelope of different size or thickness, you had better check whether it satisfies the requirements shown below. For other specific problems, ask your dealer whether the paper can be used with this printer.

### Paper width and thickness

**Table 2-2 Paper requirements**

Item	Requirements
Width	4 to 16.5 inches (102 to 419 mm).
Thickness	<p>The thicknesses of paper are indicated in grams per square meter and in pounds per bond in terms of weight, representing the maximum weights of the paper.</p> <ul style="list-style-type: none"> <li>- Single-part paper 46 g/m<sup>2</sup> (12 lbs/bond) to 100 g/m<sup>2</sup> (26 lbs/bond). For paper whose width is less than 255 mm (10 inches) the weight must be 35 g/m<sup>2</sup> (9 lbs/bond)).</li> <li>- Multi-part paper 39 g/m<sup>2</sup> (11 lbs/bond) to the weight corresponding to the number of copies and parts listed in the table below.</li> </ul> <p>Notes:</p> <ol style="list-style-type: none"> <li>1. Multi-part paper, especially with parts whose thickness or count differs from the specifications, must be tested before orders are placed.</li> <li>2. The total thickness of multi-part paper must not exceed 0.016 inches (0.40 mm). The thickness of each part must be uniform.</li> <li>3. The maximum thickness of an envelope must not exceed 0.2 inches (0.5 mm).</li> </ol>

**Table 2.2 – continued**

Item	Requirements						
Number of copies and thickness	– Carbonless/carbon-backed						
	Copies	1	2	3	4	5	6
	Part 2	64 (17)	81 (22)				
	3	49 (13)	49 (13)	81 (22)			
	4	39 (11)	39 (11)	39 (11)	81 (22)		
	5	39 (11)	39 (11)	39 (11)	39 (11)	64 (17)	
	6	39 (11)	39 (11)	39 (11)	39 (11)	39 (11)	39 (11)
	Notes:						
	1. If a four-color ribbon is used, 4-part paper must not be used.						
	2. The desired width for multi-part cut-sheet paper is less than 10 inches.						
	– Carbon-interleaved						
	Copies	1	2				3
	Part 2	50 (13)	81 (22)				
	3	46 (12)	46 (12)	81 (22)			
	Notes:						
	1. Because the carbon inserted between sheets of paper counts as one part, the number of copies must be less than 3.						
	2. If a four-color ribbon is used, carbon-interleaved 3-part paper must not be used.						
	3. Do not use carbon-interleaved paper as multi-part cut-sheet paper.						

Getting Acquainted

## Print areas

### Continuous forms:

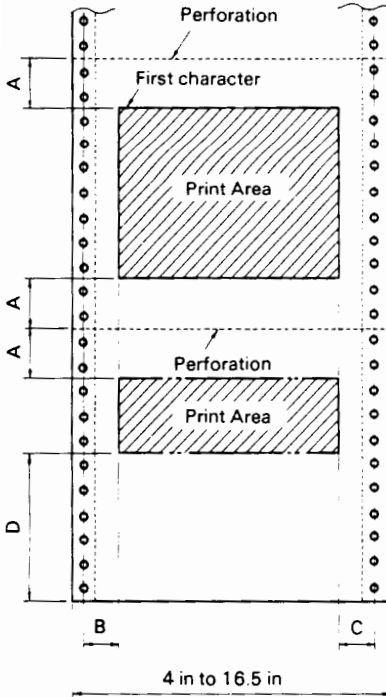

A	1 inch (25.4 mm)	
B	0.95 to 1.2 inches (24 to 30 mm)	Note 1
C	More than 0.95 inches (24 mm)	Note 2
D	About 2.9 inches (74 mm)	Note 3

#### Notes

1. For single-part paper, if a black ribbon is used, B must be more than 1/5 inch (5 mm).  
If a four-color ribbon is used, B must be more than 6/5 inch (30 mm).
2. For single-part paper, if a black or four-color ribbon is used, C must be more than 1/5 inch (5 mm).
3. Paper end is detected and printing stops when this amount of paper is left in the print area.

**Figure 2-14** Print area on continuous forms

**Cut sheet paper:**

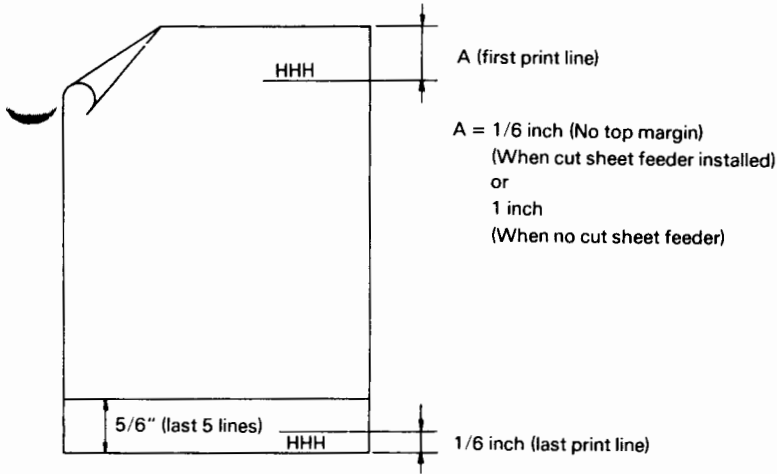

**Note:**  
The line feed pitch for the last five lines is not guaranteed.

**Figure 2-15 Print area on cut sheet paper**

**Getting Acquainted**

**Multi-part paper binding and perforations**

When using multi-part paper, note the following:

**Binding continuous forms:**

- (1) When binding continuous forms, glue the opposing margins of the paper together at spots other than pin holes and perforations, as shown below.

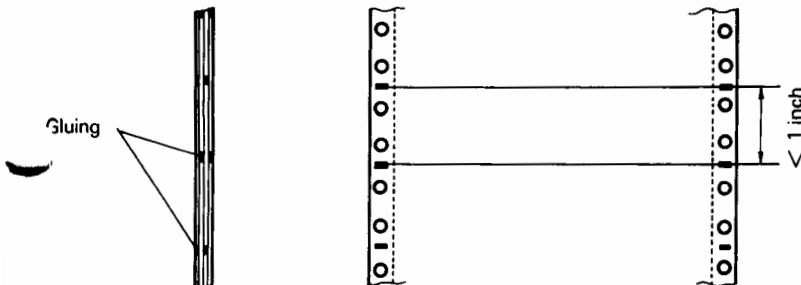

- (2) When affixing paper by gluing, crimping, or stitching, use three or fewer copies and make sure that the paper is not misaligned. If the paper is misaligned, printing must be done on every other line.

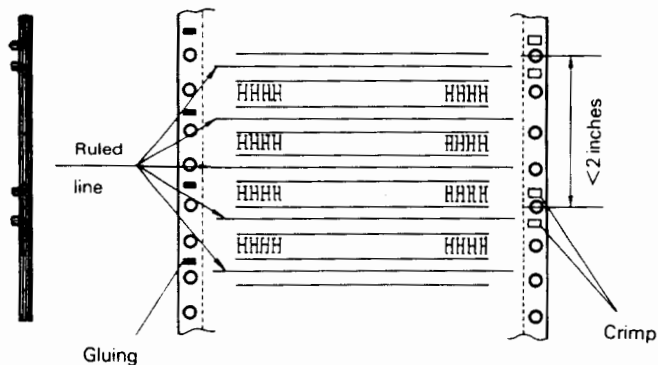

- (3) The raised part at the perforation (fold) must be 1 mm or less, with the bottom layer kept flat by force, as shown below.

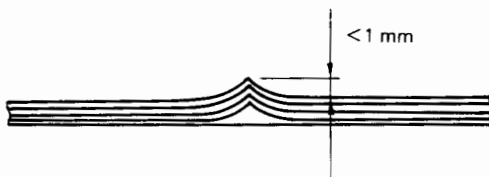

### Binding cut sheet paper:

When using carbonless/carbon-backed cut sheet paper, make it into pads that are glued at the top.

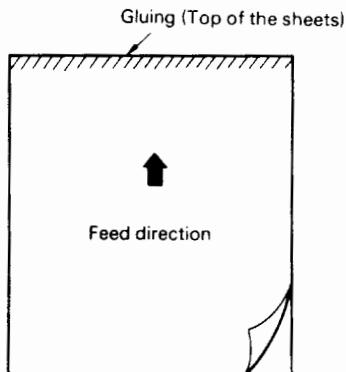



## Notes on binding:

Glue must be applied evenly to the paper and must not cause wrinkles, creases, or discoloration.

Multi-part paper must be affixed at the margins only, and paper staples must not be used.

If multi-part paper is not affixed properly, print quality may be reduced and paper folding may become difficult.

When using carbon-interleaved multi-part paper, put the carbons in the following two ways:

- (1) Gluing the carbons to the paper at the margins without including the pin hole areas.
- (2) Gluing the carbons to the paper at the margins including the pin hole areas, and making the carbon's pin holes that align with those of the paper.

## Perforations:

Weak horizontal and vertical perforations cause paper jams. Therefore, the tie to cut ratio for both types of perforations must be 1 to 3.

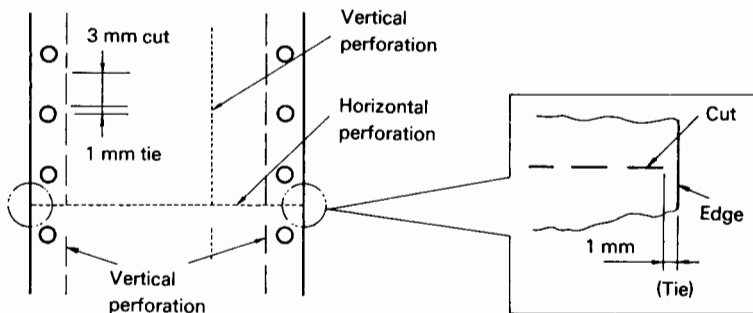

—

—

—

# SECTION 3 USING THE CONTROL PANEL

## 3.1 CONTROL PANEL LAYOUT

The control panel has a 16-digit LCD, four LED indicators, and four white buttons with upper and lower labels, as shown below:

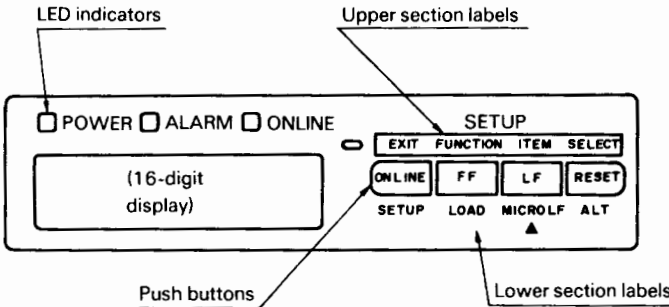

Figure 3-1 Control panel layout

Control Panel

### Indicators:

On the left of the control panel is the display section which indicates the printer status or prompt information.

#### POWER

Lights whenever power is turned on.

#### ALARM

Lights when the printer is out of paper or in other abnormal conditions.

## ONLINE

Lights when the printer is ready for communicating with the host computer.

## SETUP

Lights when the printer is in special mode operation.

## Push buttons:

On the right of the control panel are the push buttons to operate the printer. It has three sections.

### Center section (Normal mode)

Contains buttons – ONLINE, FF (form feed), LF (line feed), and RESET – The name on each button identifies the function performed by pressing the button when the printer is online, offline or in pause mode, see paragraph 3.2.

### Lower section (Alternate mode)

Contains labels – SETUP, LOAD (paper load), MICRO LF (micro line feed), and ALT (alternate) – Each label identifies the alternate function performed, by holding the ALT/(RESET) button down and then pressing the corresponding button, see paragraph 3.3.

### Upper section (Setup mode)

Contains labels – EXIT, FUNCTION, ITEM and SELECT – Each label identifies the setup function performed (in the setup mode), when the corresponding button is pressed, see paragraph 3.4.

In the following descriptions, buttons to be used are referred to as follows.

When the purpose for pressing a button is on the button, the button's name is given. When the purpose for pressing a button is on an upper or lower section label, the label's name is given followed by the button's name in brackets ( ). For example:

There are three ways used to refer to a button.

1. **RESET** – Refers to the rightmost button – When you press this button with the printer offline or pause mode to reset the printer.
2. **ELECT/(RESET)** – Refers to the same rightmost button and the upper section label – When you press this button with the printer in setup mode to start a special mode operation or select an option for a selected printer feature.
3. **ALT/(RESET)** – Refers to the same rightmost button and the lower section label – When you hold this button down to perform the alternate function of another button.

## 3.2 CENTER SECTION (NORMAL MODE)

This section contains the four buttons – ONLINE, FF, LF and RESET. These buttons are labeled with the function they perform when the printer is online, offline, or pause mode.

### ONLINE button

Press this button to change the printer between online and offline. If this button is pressed when the display shows "ON-LINE:BUSY"; the display changes to "=== PAUSE ===" and printing stops (data, that has been received but not printed, is stored in the print buffer). Press this button again to resume printing.

### FF (Form Feed) button

Press this button to execute a form feed (to the next top of form). The top of form is the print line where the print head is positioned when power is turned on. The top of form is changed when the paper is moved, by micro line feeds or by manual rotation of the platen.

### LF (Line Feed) button

Press this button to execute a line feed. Holding this button down advances the paper to the first line of the next page (Top of form position).

Control Panel

## RESET button

Press this button to reset the printer (or clear a communication error when using an RS-232C serial interface).

To reset the printer, press this button when the display shows "OFF-LINE" or "PAUSE". The display will change to "Reset Printer?". If the RESET button is pressed again, all data in the print buffer is cleared. When the printer is reset, the display will show "ON-LINE:READY".

If you do not wish to clear the data in the print buffer, press the ONLINE button (rather than RESET).

Clear an RS-232C interface communication error display, listed below, by pressing the RESET button once.

"PARITY ERROR"  
"FRAMING ERROR"  
"OVER-FLOW ERROR"  
"MODEM ERROR"

## ONLINE + FF buttons

Press these buttons to advance the paper to the "tear bar" position for tearing off continuous forms along horizontal perforation. Press the RESET button to return the paper. See Section 2.3.

## 3.3 LOWER SECTION (ALTERNATE MODE)

### /(RESET) button

Access an alternate mode function (setup, load or micro LF), by holding down the ALT/(RESET) button and then pressing the desired button in the center section of the control panel.

### SETUP/(ONLINE) button

When the SETUP/(ONLINE) button is pressed with the ALT/(RESET) button held down, the printer enters setup mode, and the button functions are labeled by the upper section of the control panel (paragraph 3.4).

### LOAD/(FF) button

Load paper into the printer, when you open the paper bail, and then press the LOAD/(FF) button with the ALT/(RESET) button held down. Either sheet or continuous form may be automatically loaded to the first print position on the page (top of form).

If you press this button without opening the paper bail, the display will show "OPEN PAPER BAIL!". What you need for recovering from this error state and loading paper is only to open the paper bail.

If continuous forms have already been loaded, press this button with the ALT/(RESET) button held down to unload the forms from the printer.

### MICRO LF/(LF) button

Enter micro line feed mode by holding the ALT/(RESET) button down and then pressing the MICRO LF/(LF) button. The display shows "MICRO LF MODE". Use the LF (▲) button to move paper up in 1/360 inch increments. Holding down the button causes continuous paper movement. Press the ALT/(RESET) button to leave this mode and get back to previous mode.

## 3.4 UPPER SECTION (SETUP MODE)

Setup mode, SEL.MENU, MENU1 (2), HARDWARE, or TOF-ADJ, allow you to select options that change the printer's printing style, page format, interface type, interface characteristic, etc.

Additional functions performed in setup mode are SAVE, LIST, DEFAULT, SELF-TST, HEX-DUMP, and V-ALNMNT.

In setup mode the four buttons are defined as follows:

### EXIT/(ONLINE) button

When this button is pressed the printer leaves setup mode and returns to "ON-LINE:READY".

### FUNCTION/(FF) button

When this button is pressed the printer steps from function to function.

### ITEM/(LF) button

This button steps the printer from item to item (within a function) or starts and stops an operation.

### SELECT/(RESET) button

This button steps the printer from option to option (within an item) or starts and stops an operation.

**NOTE:**

Holding the button (FUNCTION/(FF), ITEM/(LF), or SELECT/(RESET)) down automatically selects the functions, items, or options sequentially.



The display changes in the following way as you press the above four buttons.

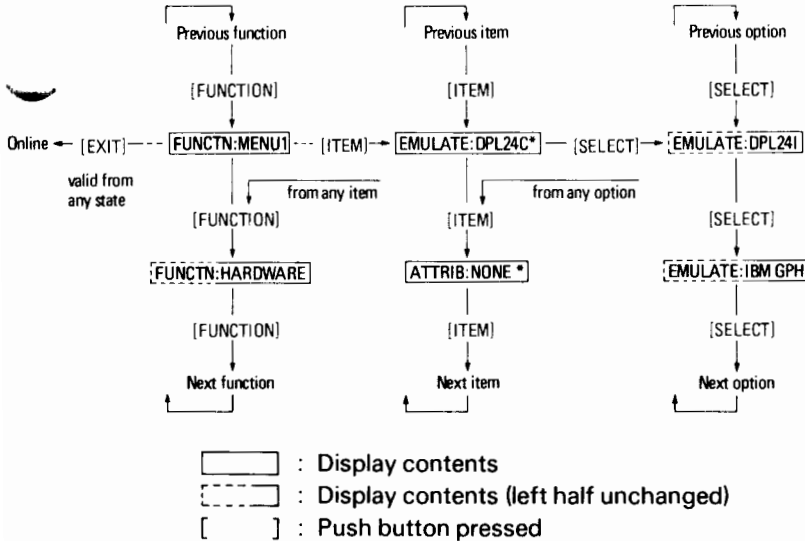

Figure 3-2 Display transition in setup mode

### 3.4.1 Setup Mode Structure

Setup mode is designed using a tree structure of the following type:

- Top level: Function
- Middle level: Item
- Bottom level: Selectable option

At the function level, the first eight digits of the display show "FUNCTN:" and the remaining digits show the name of the function.

Example: When the display shows "FUNCTN :MENU1":  
Function is "MENU1"

and

When the display shows "FUNCTN :HARDWARE":  
Function is "HARDWARE"

Control Panel

At the item level, the display shows both the item and selectable option.

Example: When the display shows "QUALITY:LETTER":  
Function is "MENU1" or "MENU2".  
Item is "QUALITY".  
Selectable option is "LETTER".

and

When the Display shows "FEEDER:NONE":  
Function is "HARDWARE".  
Item is "FEEDER".  
Selectable option is "NONE".

The last location of the display shows an asterisk (\*) if the selectable option being displayed has been saved to nonvolatile memory, using the SAVE function, see paragraph 3.9.

Refer to the following flowchart for a visual presentation of how the setup mode is organized:

### 3.5 FUNCTION LEVEL

Enter setup mode by holding down the ALT/(RESET) button and then pressing the SETUP/(ONLINE) button. The display will briefly show "⏏JP MODE" then "FUNCTN :SEL.MENU".

When the printer is in the FUNCTN (function) level of setup mode, the display will show "FUNCTN:" and then one of the following functions: SEL.MENU, MENU1 (2), HARDWARE, TOF-ADJ, SAVE, LIST, DEFAULT, SELF-TST, HEX-DUMP, and V-ALNMNT.

An explanation of each function is shown below:

**Table 3-1 Function chart**

FUNCTN : SEL.MENU	Allows you to select one of two menus (MENU1 or MENU2) as print parameter settings.
FUNCTN : MENU1 or 2	Allows you to select character, and page format options. Two sets of menus are provided.
FUNCTN : HARDWARE	Allows you to select the printer's hardware conditions and interface type and options.
FUNCTN : TOF-ADJ	Allows you to adjust the top-of-form position of paper.
FUNCTN : SAVE	Allows you to store selected options in non-volatile memory (not affected by power on/off).
FUNCTN : LIST	Allows you to print selected options on the paper.
FUNCTN : DEFAULT	Returns the printer's selectable options to the factory default settings.
FUNCTN : SELF TST	Allows you to perform the self-test printing.
FUNCTN : HEX DUMP	Allows you to print the data, received from the host, in hexadecimal.
FUNCTN : V-ALNMNT	Allows you to adjust character displacement in bidirectional printing.



In setup mode, you move from function to function each time you press the FUNCTION/(FF) button. When the display shows the function you wish to enter, press the ITEM/(LF) button.

## 3.6 ITEM LEVEL

The item level is the middle level of the tree structure. Enter the item level by pressing the ITEM/(LF) button when the display shows "FUNCTN : " followed with the name of a function (such as "MENU" or "HARDWARE").

When the printer is in the item level of setup mode, the display will show the name of an item (such as "QUALITY:" or "LANGUGE:") followed with the name of a selectable option (such as "LETTER" or "DRAFT").

As shown in the previous flowchart and explained in the following paragraphs, there are multiple items you may select in the MENU, HARDWARE and TOF-ADJ functions. In the remaining six functions you select an action (SAVE, LIST, DEFAULT, SELF-TST, HEX-DUMP, and V-ALNMNT).

## 3.7 MENU FUNCTION SELECTIONS

### 3.7.1 SEL.MENU Function

The SEL.MENU function has two menus, MENU1 and MENU2, with the same configuration. You can set different options in each menu so that you can select a set of option settings suitable for your routine job by just selecting a menu; for example, MENU1 for word processing and MENU2 for graphics.

When the display shows "FUNCTN :SEL.MENU" and the ITEM button is pressed, the printer enters the MENU select function and the display shows "SELECT :MENU1".

First, press the SELECT/(RESET) button to select one of the two menus, then press the FUNCTION/(FF) button.

MENU is selected and the display goes back to the function level.

## 3.7.2 MENU1 (MENU2) Function

When the display shows "FUNCTN:MENU1" or "FUNCTN:MENU2" in the function level and the ITEM/(LF) button is pressed, the printer enters the MENU function and the display shows the first item "QUALITY:" in the menu.

To move from item to item in the menu, press the ITEM/(LF) button. The display will show the next item and its current selection.

Example When "QUALITY:LETTER" shows in the display, it means that under the item "QUALITY", the current selection is "LETTER".

To change the current selection, press the SELECT/(RESET) button until the selectable option you want to select is displayed, then press the ITEM/(LF) button, your selection is set until power to the printer is turned off (unless the selection has been saved; see paragraph 3.9). The next item is shown on the display.

When all your selections are completed, press the FUNCTION/(FF) button to go back to the function level or press the EXIT/(ONLINE) button to leave the setup mode.

If a button other than the SELECT/(RESET) button is used, options cannot be changed. Don't forget to return the options to the original values when you operate the SELECT/(RESET) button by mistake or for other than the purpose of changing options, that is, for checking what kinds of options are contained in an item.

The following chart provides an explanation of the items and selectable options in the MENU function:

**Table 3-2 Menu function selectable options**

No.	Item	Selectable option
1	QUALITY:	Print quality: LETTER* – Letter quality is valid for Courier 10, Prestige Elite 12, Boldface and optional card fonts. REPORT – Report quality has less quality than letter but has higher printing speed. DRAFT – Draft quality is a resident font in the printer.
2	FONT:	Print font: COUR 10* – Courier 10 PRSTG12 – Prestige Elite 12 COMPRSD – Compressed patterns corresponding to 18 CPI BOLDFCE – Boldface PS FNTCRDn – Font number or name (or abbreviation) in the font card. Displayed only when an optional font card is installed (For details of the font card, Appendix B) DWNLOD0 or DWNLOD1 – Font 0 or font 1 in the download RAM
3	CHAR SP:	Characters per inch: 10 CPI*, 12 CPI, 15 CPI, 17 CPI, 18 CPI, 20 CPI, or PROP SP (proportional spaced)  Some characters may overlap other characters if the specified spacing is narrow.  Proportional spacing is valid for any selection of type style and print quality.
4	LINE SP:	Lines per inch: 6 LPI*, 8 LPI, 3 LPI, or 4 LPI

\* Indicates factory setting.

**Table 3-2 – continued**

No.	Item	Selectable option
5	EMULATE:	<p>Command emulation:                      Many kinds of emulation are available in this printer. The following shows printers for the command emulation mode to be displayed and selected.</p> <p>DPL24C* and DPL24I – Fujitsu DPL24C and DPL24I printers                      IBM GPH – IBM Graphics printer                      IBM PRO – IBM Proprinter XL                      FX-80 and JX-80 – EPSON FX-80/100 and JX-80 printers                      DPL24D and DIABLO – Fujitsu DPL24D and Diablo 630 printers</p>
6	ATTRIB:	<p>Character attribute:</p> <p>NONE* – Standard character                      ITALICS – Italic character                      SHADOW – Double striked with slight shift                      BOLD – Double striked at the same position</p>
7	PAGE LG:	<p>Page length in inch units:                      11.0 IN* (letter size), 11.6 IN, 12.0 IN, 14.0 IN, 18.0 IN, 3.0 IN, 3.5 IN, 4.0 IN, 5.0 IN, 5.5 IN, 6.0 IN, 7.0 IN, 8.0 IN, 8.5 IN</p>
8	COLOR:	<p>Printed color:                      BLACK*, YELLOW, MAGENTA (red), or CYAN (blue)</p>
9	LFT END:	<p>Left end position offset:                      You can set the left margin at column 1 through 41. The selected number plus software left margin spacing determines the position of the actual left margin. The column is determined based on the character spacing currently selected, but 12 CPI (Elite pitch) is assumed for proportional spacing.</p> <p>1 COLM*, 2 COLM, ..., 41 COLM</p>

Control Panel

\* Indicates factory setting.

Table 3-2 – continued

No.	Item	Selectable option
10	TOP MRG:	Top margin: Set top margin at line 1 * through 7.
11	LANGUGE:	Language: USA *, UK, GERMAN, FRENCH, ITALIAN, SPANISH, SWEDISH, FINISH, DANISH, or NORWEGN (Norwegian)  The character set for the Swedish and Finnish languages as well as for the Danish and Norwegian languages are the same.
12	CHR SET:	Character set: SET 2 * – Uses IBM Graphics printer character set 2  SET 1 – Uses IBM Graphics printer character set 1.  If a font in the font card or download RAM is selected and SET 2 is selected, the character set in the card or download RAM is used. (User-designed character set) For the character sets, see Appendix F.
13	GRPH LF:	Graphic line feeding: IBM GPH* – IBM Graphics printer or equivalent  FX-80 – EPSON FX-80/JX-80 printer or equivalent  Graphic line feeding: Your printer in DPL24C or DPL24I emulation mode is compatible with the two types of printer given above, but command set includes different definitions of some line spacing commands of the same codes.  This setting is meaningful only for DPL24C and DPL24I emulations and when one of other emulations is selected this is not displayed.

\* Indicates factory setting.



**Table 3-2 – continued**

No.	Item	Selectable option
14	PRF SKP:	Perforation skip:  Skip 1 inch over the perforation at the end of each continuous form sheet, or print through it*.
15	WIDTH:	Paper width: Select 13.6 IN* or 8 IN for the width of paper used.  This setting determines the right end print position (see item 20).
16	ZEROFNT: (Resident fonts only)	Zero character's font: Select NO-SLSH* for 0 and SLASH (with slash) for Ø.  Ineffective for font card and download fonts.
17	DC3-CDE:	DC1/DC3 code: Enable* or Disable DC3/DC1 codes.  Print data received between a DC3 and DC1 code is ignored when enabled.
18	CR-CODE:	CR code definition: Select Carriage Return without a Line Feed* or a Line Feed with each Carriage Return.
19	LF-CODE:	LF code definition: Select Line Feed (not only LF code (0A hexadecimal) but also the all of the other paper feed commands) without a Carriage Return or Carriage Return with each Line Feed*.
20	RGHTEND:	Auto carriage return: Select whether an Auto CR (Carriage Return plus Line Feed) occurs when the print head reaches the physical right end determined by Item 15 "WIDTH".  WRAP* – Auto CR OVR-PRNT – No Auto CR (overprinting at the right end)

Control Panel

\* Indicates factory default setting.

## 3.8 HARDWARE FUNCTION SELECTIONS

When the display shows "FUNCTN :HARDWARE" and the ITEM button is pressed, the printer enters the function "HARDWARE" and the display shows the current selection.

To move from item to item in this function, press the ITEM/(LF) button. The display will show the next item and the current selection.

Example: When "INTRFCE:SERIAL" shows in the display, it means that under the item "INTRFCE", the current selection (interface type) is "SERIAL".

To change the current selection, press the SELECT/(RESET) button until the selectable option you want to select is displayed, then press the ITEM/(LF) button, your selection is set until power to the printer is turned off (unless the selection has been saved, see paragraph 3.9). The next item is shown on the display.

When all your selections are completed, press the FUNCTION/(FF) button to go back to the function level or press the EXIT/(ONLINE) button to leave the setup mode.

The following chart provides an explanation of the items and selectable options in the HARDWARE function:

**Table 3-3 Hardware function selectable options**

No.	Item	Selectable option														
1	SPEED:	Speed limitation control for quiet printing: NORMAL* – print without limitation MEDIUM – print with spacing speed limitation (medium noise level) QUIET – print with printing speed limitation (lower noise level)														
2	PPR OUT:	Paper-out detection control: <table border="1" data-bbox="398 504 907 715"> <thead> <tr> <th data-bbox="398 504 544 587" rowspan="2">Option</th> <th colspan="2" data-bbox="544 504 907 544">Control</th> </tr> <tr> <th data-bbox="544 544 760 587">Continuous form</th> <th data-bbox="760 544 907 587">Cut sheet</th> </tr> </thead> <tbody> <tr> <td data-bbox="398 587 544 627">DETECT</td> <td data-bbox="544 587 760 627">A</td> <td data-bbox="760 587 907 627">A</td> </tr> <tr> <td data-bbox="398 627 544 667">CNTONLY*</td> <td data-bbox="544 627 760 667">A</td> <td data-bbox="760 627 907 667">B</td> </tr> <tr> <td data-bbox="398 667 544 715">IGNORE</td> <td data-bbox="544 667 760 715">B</td> <td data-bbox="760 667 907 715">B</td> </tr> </tbody> </table> Control A – Stop printing when out-of-paper* is detected. Control B – Keep on printing even if out-of-paper is detected.	Option	Control		Continuous form	Cut sheet	DETECT	A	A	CNTONLY*	A	B	IGNORE	B	B
Option	Control															
	Continuous form	Cut sheet														
DETECT	A	A														
CNTONLY*	A	B														
IGNORE	B	B														
3	PRT DIR:	Print direction: Select Bi-directional* or Uni-directional printing.														
4	BUZZER:	Buzzer activation: Enable* or disable the buzzer when an error occurs.														
5	WORD LG:	Word length of interface data: Select 8-BIT* or 7-BIT word length.  Bit image graphics always uses 8-bit data.														
6	BUFFER:	Input buffer allocation: This printer has the 32K byte buffer used for input data and downloaded character pattern data.  Select 256 BYTE, 2K BYTE, 8K BYTE*, or 24K BYTE for input buffer.														

\* Indicates factory setting.



Table 3-3 – continued

No.	Item	Selectable option																																																							
7	FEEDER: (ASF300 only)	Cut sheet feeder installation and type: NONE* – No cut sheet feeder is installed. SNGL-BN or DBL-BIN – The number of bins provided with your feeder.  Note:  If you use the SF23x cut sheet feeder, the printer can recognize that installation. So, in this case, this selection has no effect.																																																							
8	INTRFC:	Interface type: Select PARALEL* or SERIAL interface.																																																							
NOTE: The following items and selectable options are shown only when the serial interface type is selected.																																																									
9	FORMAT:	Data format selection: See the "Appendix C" for details of the data format.  <table border="1" data-bbox="521 804 1034 1310"> <thead> <tr> <th></th> <th>No. of data bits</th> <th>Parity bit</th> <th>Stop bit</th> <th>Total bits</th> </tr> </thead> <tbody> <tr> <td>8NONE 1*</td> <td>8</td> <td>None</td> <td>1</td> <td>10</td> </tr> <tr> <td>8NONE 2</td> <td>8</td> <td>None</td> <td>2</td> <td>11</td> </tr> <tr> <td>8 ODD 1</td> <td>8</td> <td>Odd</td> <td>1</td> <td>11</td> </tr> <tr> <td>8EVEN 1</td> <td>8</td> <td>Even</td> <td>1</td> <td>11</td> </tr> <tr> <td>7MARK 1</td> <td>7</td> <td>Mark</td> <td>1</td> <td>10</td> </tr> <tr> <td>7SPCE 1</td> <td>7</td> <td>Space</td> <td>1</td> <td>10</td> </tr> <tr> <td>7 ODD 1</td> <td>7</td> <td>Odd</td> <td>1</td> <td>10</td> </tr> <tr> <td>7EVEN 1</td> <td>7</td> <td>Even</td> <td>1</td> <td>10</td> </tr> <tr> <td>7 ODD 2</td> <td>7</td> <td>Odd</td> <td>2</td> <td>11</td> </tr> <tr> <td>7EVEN 2</td> <td>7</td> <td>Even</td> <td>2</td> <td>11</td> </tr> </tbody> </table> * Total number of bits includes a start bit. None: No parity bit is assigned. Mark: Parity bit is always logical 1. Space: Parity bit is always logical 0.		No. of data bits	Parity bit	Stop bit	Total bits	8NONE 1*	8	None	1	10	8NONE 2	8	None	2	11	8 ODD 1	8	Odd	1	11	8EVEN 1	8	Even	1	11	7MARK 1	7	Mark	1	10	7SPCE 1	7	Space	1	10	7 ODD 1	7	Odd	1	10	7EVEN 1	7	Even	1	10	7 ODD 2	7	Odd	2	11	7EVEN 2	7	Even	2	11
	No. of data bits	Parity bit	Stop bit	Total bits																																																					
8NONE 1*	8	None	1	10																																																					
8NONE 2	8	None	2	11																																																					
8 ODD 1	8	Odd	1	11																																																					
8EVEN 1	8	Even	1	11																																																					
7MARK 1	7	Mark	1	10																																																					
7SPCE 1	7	Space	1	10																																																					
7 ODD 1	7	Odd	1	10																																																					
7EVEN 1	7	Even	1	10																																																					
7 ODD 2	7	Odd	2	11																																																					
7EVEN 2	7	Even	2	11																																																					

\* Indicates factory setting.

**Table 3-3 — continued**

No.	Item	Selectable option
10	BAUD RT:	Baud (1 bit per second) rate: 9600*, 19200, 600, 1200, 2400, or 4800  Selecting a speed lower than that of your computer (or modem) causes an overflow error in your printer.
11	PROTOCL:	Communication protocol: Set XON/XOFF*, DC1/DC3, DTR (Data Terminal Ready), REV CHL (Reverse Channel) or ETX/ACK protocol.
12	DUPLEX:	Duplex mode of data transmission:  FULL* — Simultaneously transmissible in opposite directions. HALF — Transmissible in either direction, but not simultaneously.

\* Indicates factory setting.

Control Panel

## 3.9 SAVE FUNCTION

When the display shows "FUNCTN :SAVE" and either the ITEM (LF) or SELECT (RESET) button is pressed, the display will briefly show "SAVING NOW!!" and the currently selected options will be saved in non-volatile memory. If you do not perform this operation, your selections will be lost when power is turned off (temporary selections). Saved selections show an asterisk (\*) in the last position of the display.

## 3.10 LIST FUNCTION

When the display shows "FUNCTN :LIST" and either the ITEM (LF) or SELECT (RESET) button is pressed, the printer will print all selected options.

This function is provided for checking the options currently stored in the RAM by the SEL.MENU, MENU1 (2), and HARDWARE setting functions. It does not display the contents of non-volatile memory. Therefore, to check whether the options are correctly stored in non-volatile memory execute this function after turning power off and on or after performing the reset operation to instruct the printer to reread the contents of non-volatile memory.

Figure 3-4 is a printout of a listing of the contents set at the factory.

FUNCTION:SEL.MENU  
 SELECT :MENU1

FUNCTION:	MENU1	MENU2
QUALITY:	LETTER	LETTER
FONT :	COUR 10	COUR 10
CHAR SP:	10 CPI	10 CPI
LINE SP:	6 LPI	6 LPI
EMULATE:	DPL24C	DPL24C
ATTRIB :	NONE	NONE
PAGE LG:	11.0 IN	11.0 IN
COLOR :	BLACK	BLACK
LFT-END:	1 COLM	1 COLM
TOP-MRG:	1 LINE	1 LINE
LANGUGE:	USA	USA
CHR-SET:	SET 2	SET 2
GRPH-LF:	IBM-GPH	IBM-GPH
PRF-SKP:	NO-SKIP	NO-SKIP
WIDTH :	13.6 IN	13.6 IN
ZEROFNT:	NO-SLSH	NO-SLSH
DC3-CDE:	ENABLE	ENABLE
CR-CODE:	CR ONLY	CR ONLY
LF-CODE:	LF & CR	LF & CR
RGHTEND:	WRAP	WRAP

FUNCTION:HARDWARE  
 SPEED :NORMAL  
 PPR-OUT:CNTONLY  
 PRT-DIR: BI-DIR  
 BUZZER :ON  
 WORD-LG: 8 BIT  
 BUFFER : 8KBYTE  
 FEEDER :NONE  
 INTRFCE:PARALEL

Control  
 Panel

Figure 3-4 List function

## 3.11 DEFAULT FUNCTION

When the display shows "FUNCTN :DEFAULT" and either the ITEM/(LF) or SELECT/(RESET) button is pressed, the display will briefly show "Setting Default!", and then show "FUNCTN :DEFAULT".

This function makes the contents of MENU1 and MENU2 to the factory default settings.

## 3.12 SELF TEST FUNCTION

When the display shows "FUNCTN :SELF TST" and either the ITEM/(LF) or SELECT/(RESET) button is pressed, the display changes to "SELF TEST PRINT" and the printer will print a SELF-TEST that shows:

- Panel button prompt listing
- Firmware revision level
- Self-test printing pattern

If, during the SELF TST printing operation, either the ITEM/(LF) or SELECT/(RESET) button is pressed, the Display shows "===PAUSE===" and the printer will stop printing.

If either the ITEM/(LF) or SELECT/(RESET) button is pressed when "===PAUSE===" is displayed, the SELF TST printing will continue.

Press the FUNCTION/(FF) button to return to the FUNCTN level.

**NOTE:**

You can also start the self-test by turning the POWER switch on while holding down the FUNCTION/(FF) button.



=== SELF TEST PRINTING ===

ACTION	BUTTON
Exit to normal mode	< ONLINE >
Return to main Function menu	< F F >
Use printing	< L F >
Pause printing	< RESET >

1 Software Revision: IC1A , IC2A (D202)

2 Repeat Printing



Figure 3-5 Self-test function

### 3.13 HEX DUMP FUNCTION

When the display shows "FUNCTN :HEX DUMP" and either the ITEM/(LF) or SELECT/(RESET) button is pressed, the printer will enter HEX DUMP mode and the display will show "HEX DUMP:READY". All subsequent data, sent to the printer, will be printed in hexadecimal and the display changes to "HEX DUMP:BUSY". One print line contains values for 16 characters.

If, during the HEX DUMP printing operation, either the ITEM/(LF) or SELECT/(RESET) button is pressed, the display shows "===PAUSE===" and the printer will stop printing.

If either the ITEM/(LF) or SELECT/(RESET) button is pressed when "===PAUSE===" is displayed, the Hex dump printing will continue.

Press the FUNCTION (FF) button to return to FUNCTN level.

=== HEX DUMP PRINTING ===																
ACTION																
BUTTON																
Exit to normal mode																< ONLINE >
Return to main Function menu																< F F >
Pause printing																< L F >
Pause printing																< RESET >
0	1	2	3	4	5	6	E	F	0123456789ABCDEF							
00	01	02	03	04	05	0D	0E	0F	.....							
10	11	12	13	14	15	1D	1E	1F	.....							
20	21	22	23	24	25	2D	2E	2F	!"#\$%&'()*+,-./							
30	31	32	33	34	35	3D	3E	3F	0123456789:;<=>?							
40	41	42	43	44	45	4D	4E	4F	@ABCDEFGHIJKLMNO							
50	51	52	53	54	55	5D	5E	5F	PQRSTUVWXYZ[\ ]^_							
60	61	62	63	64	65	6D	6E	6F	`abcdefghijklmnop							
70	71	72	73	74	75	7D	7E	7F	pqrstuvwxyz{ }~.							
80	81	82	83	84	85	8D	8E	8F	ÇüéâãäåçèéêëìíîËÀ							
90	91	92	93	94	95	9D	9E	9F	ÉæŒðóôûñÿöÜÇËŸřf							
A0	A1	A2	A3	A4	A5	A0	AE	AF	áíóúñÑæøç~¼½¾¿							
B0	B1	B2	B3	B4	B5	B0	BE	BF	.....							
C0	C1	C2	C3	C4	C5	C0	CE	CF	.....							
D0	D1	D2	D3	D4	D5	D0	DE	DF	.....							
E0	E1	E2	E3	E4	E5	E0	EE	EF	αβΓΔΕΖΗΘΙΚΛΜΝΞΟΠΡ							
F0	F1	F2	F3	F4	F5	F0	FE	FF	±∓≥≤∫∫÷≈°•√ⁿ²■							

Figure 3-6 Hex-dump function  
B-69337...B

## 3.14 VERTICAL ALIGNMENT FUNCTION

This function is typically used by maintenance personnel to adjust vertical alignment of bidirectionally printed characters. You may also use this procedure as follows:

1. When the display shows "FUNCTN:V-ALNMNT" and either the ITEM/(LF) or SELECT/(RESET) button is pressed, the display will show "VER.ALIGNMENT:n" and the printer, in bidirectional mode, will print a series of vertical bars at the letter quality print speed.

You can also start this function by holding the ONLINE button down while turning power on.

The vertical bars will line up, when printing in this mode.

"n" is set at the factory between -8 and +7 for best alignment of these bars.

2. When the alignment is correct, press the FF button. If the print speed is the letter quality one, the printer changes the print speed to the report quality one (double the letter quality speed); if the report quality, it changes to the draft quality one (three times the letter quality speed). That is, the printer can adjust the vertical alignment of each quality separately.

If the alignment is not correct:

Press the LF button to decrease the value of "n" and move the vertical bars towards the right side.

Press the RESET button to increase the value of "n" and move the vertical bars towards the left side.

3. If draft quality printing is aligned, press the ONLINE button. Then the display shows "SAVING NOW!!", and then returns to "ONLINE:READY".

```

=== VERTICAL ALIGNMENT ADJUSTING ===
ACTION                               BUTTON
Save and exit to normal mode         < ONLINE >
Change printing speed                < F F >
Shift backward line to the right     < L >
Shift backward line to the left     < RESET >

```

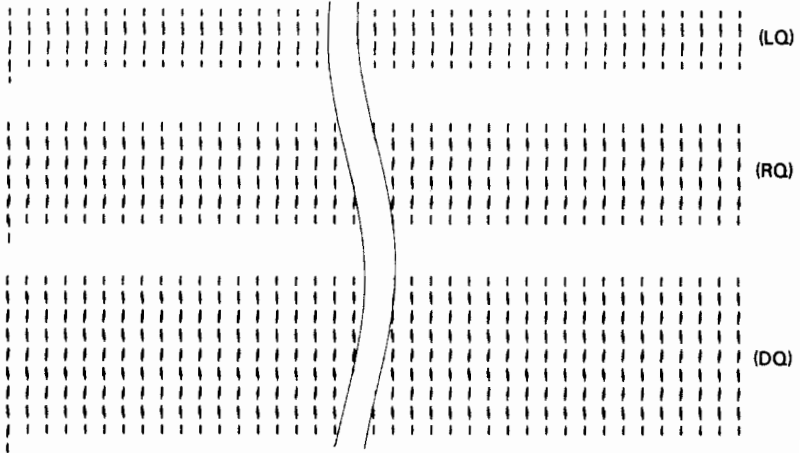

Figure 3-7 Vertical alignment function

## 3.15 TOP OF FORM ADJUSTMENT FUNCTION

When paper is loaded, this printer sets the top of form (first print line) to the position determined by a TOF MRG option set up in item 10 of the MENU function.

This function allows you to adjust the top-of-form position.

1. When the display shows "FUNCTN:TOF-ADJ" and the ITEM/(LF) button is pressed, the display changes to "ORIGIN:1 INCH".

While the ORIGIN is displayed, the position can be roughly selected to 1 inch or 1/6 inch from the top of the paper by pressing the SELECT(RESET) button.

- 2. Press the ITEM/(LF) button again; the display changes to "FINEADJ:n/60IN".

"n" is from +8 to -7 and set to 0 at the factory. The position can be easily adjusted in steps of n/60 inch offset (from -7/60 inch to +8/60 inch) by pressing the SELECT/(RESET) button.

- 3. Press the FUNCTION/(FF) button when the necessary offset is obtained. The display returns to the function level.

### 3.16 ERROR MESSAGES

The printer's error messages and the action needed to correct the error is shown in the following charts:

**Table 3-4 Operational error messages**

Error message	Cause	Recovery
FRONT COVER OPEN ERROR	The front cover is open or removed.	*Close the front cover. *Do not open the front cover during print head positioning after the cover is closed.
PAPER OUT ERROR	Printer has detected paper out state.	*Load new paper.
FEEDER ERROR	The hopper of the cut sheet feeder runs out of paper, or paper jam occurs.	*Put new sheets in the hopper, and load the paper. *Remove paper jam, and load new paper.

Control Panel

**Table 3-5 Paper handling error messages**

Error message	Cause	Recovery
OPEN PAPER BAIL!	Auto-load switch is pressed while paper bail is closed.	*Open the paper bail.
CLSE PAPER BAIL!	Printer requests the operator to close the paper bail.	*Close the paper bail.

Clear the following error messages by pressing the RESET button.

**Table 3-6 Serial interface error messages**

Error message	Cause	Recovery
PARITY ERROR	Printer has received data with incorrect parity.	*Check parameters of "FORMAT" or "BAUD RT". *Check interface cable.
FRAMING ERROR	Printer has received data with incorrect format.	*Check parameters "FORMAT" or "BAUD RT". *Check interface cable.
OVER-FLOW ERROR	Input buffer has overflowed.	*Check parameters of "PROTOCL" or "FORMAT". *Check interface cable.
MODEM ERROR	Printer has received data with incorrect modem control signal.	*Check interface cable.

**Table 3-7 Memory error messages**

Error message	Cause	Recovery
ROM SUM ERROR! RAM R/W ERROR!	An error was detected during testing of the ROM or RAM memory.	*Consult Maintenance personnel if either message is displayed repeatedly.
ILLEGAL CARD!	An illegal card is inserted.	*Check card type. *Consult your dealer.

**Table 3-8 Downloading error message**

Error message	Cause	Recovery
DOWN-LOAD ERROR	The format of the down load data is incorrect.	*Check down load data.

**Table 3-9 Mechanical error messages**

Error message	Cause	Recovery
DRIVER ALARM! POWER ALARM! FAN ALARM! or LEFT END ALARM!	These are warning messages that indicate a possible mechanical problem.	*Consult maintenance personnel if any of these messages is displayed repeatedly.

Control Panel





## SECTION 4

# PRINTER CARE



This section describes the printer's initialization cycle, gives basic troubleshooting hints, explains the cleaning and lubricating procedures, and describes how to repack the printer for storage or transport.

## 4.1 PRINTER INITIALIZATION

A printer initialization cycle occurs when:

1. The power switch is turned on.
2. An Input Prime signal is received from the host system with parallel interface.



An escape code sequence for initializing your printer is received from the host system.

A normal initialization cycle causes the printer to:

Light the POWER lamp.

Perform a basic internal check on its circuits.

Display "INTERNAL TEST" briefly and then show "INTERNAL TEST OK" (power-on initialization only).

If the internal test detects an error, the display will show the error.

The platen slightly rotates backward and forward to clear gear backlash when paper path lever is set to the front of the printer.



The print head moves to the left side frame.

The printer enters the online mode (if paper is inserted).

The display will show "PAPER OUT ERROR" if the paper release lever is towards the front of the printer and no paper is in the forms tractors.

When the initialization cycle is complete, the display shows "ON READY".

## 4.2 REMOVING A PAPER JAM

1. Turn power off and open the front cover. Otherwise, you may have your fingers caught by the print head carriage because the carriage will move if the bail lever is operated during jam removal.
2. Pull the paper path lever towards the front of the printer.
3. Place the paper thickness lever into position D (manual version only).
4. Place the print head at either end of the print line.
5. Carefully pull the jammed paper from the paper path. Try to avoid tearing the paper.
6. Rotate the platen knob and try to remove all scraps of paper from beneath the platen if any.
7. Move the print head to the center of the print line.
8. Insert fresh paper into printer and rotate the platen knob, to advance the paper through the printer and push out any scraps of paper.
9. Put the paper path lever and paper thickness lever into their operating positions and close the front cover.
10. Turn power on, load paper and print.

# 4.3 REPLACING FUSE

If your printer goes off during operation or does not come on at the start, the AC line fuse of your printer may have blown out. First, you should check that the power source at the outlet is not interrupted and the power cord is not disconnected.

A blown fuse indicates that an overcurrent flowed through your printer for some reason. If the cause is unknown, be careful when turning power on again after replacing the fuse. If the fuse blows again, contact your dealer.

The replacement procedure is as follows:

1. Unplug the power cord. (Turning off the power switch is not sufficient.)
2. Turn the fuse holder counterclockwise with your finger or a screwdriver, and remove the holder together with the blown fuse.

Put a new fuse into the fuse holder.

4. Put the fuse holder back into the socket by reversing step 2.

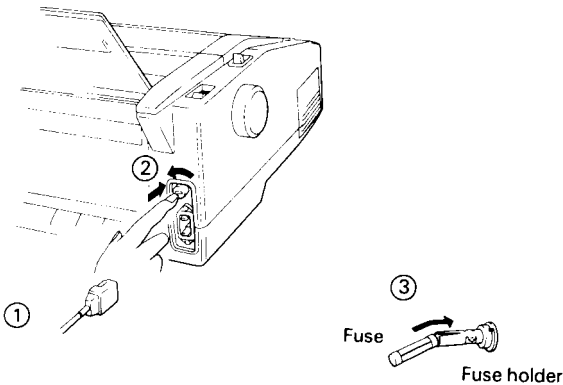

Figure 4-1 Replacing the fuse

Printer  
Care

(For German users)

## Austausch der Sicherung

Wenn der Drucker beim Betrieb plötzlich aussetzt oder beim Einschalten nicht arbeiten will kann es sein, daß die Netzstromsicherung des Druckers durchgebrannt ist. Natürlich müssen Sie auch nachprüfen, ob Strom im Netz ist und ob der Netzstecker ein gesteckt ist. Eine durchgebrannte Sicherung deutet darauf hin, daß aus irgendeinem Grund ein zu starker Strom durch den Drucker geflossen ist. Wenn die Ursache dafür nicht festgestellt werden kann, seien Sie beim erneuten Einschalten des Druckers nach Austausch der Sicherung vorsichtig. Wenn die Sicherung erneut durchbrennt, wenden Sie sich an Ihren Fachhandler. Die Sicherung wird wie folgt ausgetauscht;

1. Das Netzkabel aus der Steckdose ziehen (einfaches Ausschalten des Gerätes reicht nicht aus).
2. Den Sicherungshalter mit einem Finger oder einem Schraubenzieher gegen den Uhrzeigereinn drehen und den Halter zusammen mit der druchgebrannten Sicherung entnehmen.
3. Eine neue Sicherung mit gleichem Nennwert einlegen.
4. Die Sicherung in die Halterung einstecken.

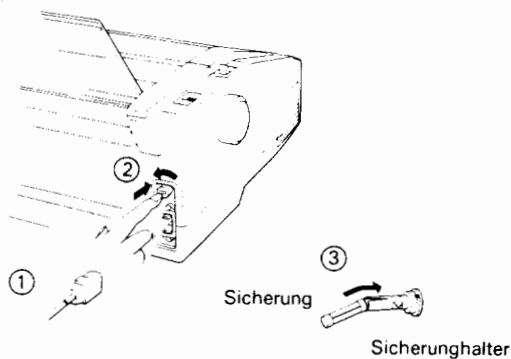

**Abb. 4-1 Austausch der sicherung**

## 4.4 CLEANING AND LUBRICATING

**CLEANING AND LUBRICATING NOTES:**

Printer lubrication is generally not required and is best performed by a service technician.

Do not use alcohol to clean rubber parts (platen, rollers, etc.). Alcohol may cause the rubber to harden.

Operator maintenance is limited to cleaning the printer, ensuring there is lubrication on the print head guide shaft, and cleaning the platen as follows:

Ensure power is off and the AC power cord is disconnected before cleaning or lubricating the printer.

1. Clean the outer surfaces of the printer with a soft cloth dampened with a mild detergent.

Use a small vacuum cleaner to remove accumulations of paper dust and particles from inside the printer.

3. Use a platen cleaner to remove ink from the platen and paper rollers.
4. Apply a small amount of platen cleaner to a cloth, place the cloth against the platen (or paper rollers) and rotate the platen knob.
5. Dry the platen by applying a dry cloth to the platen.
6. Avoid getting platen cleaner inside the printer.

**CAUTION:**

Be careful not to plug up the sensor holes with removed dust.

Printer Care

## 4.5 BASIC TROUBLESHOOTING

Your printer is designed to provide reliable operation. If it happens to malfunction use Table 4-1 to help identify and resolve the difficulty.

Check your computer and application software manual for additional suggestions. If self-test performs correctly, you should check the interface connection and other elements in the system.

**Table 4-1 Troubleshooting hints**

Symptom	Check
POWER lamp fails to light.	Power cord and connection. Fuse, replace if bad.
Printer will not initialize.	Carriage for easy side to side movement.
Display fails to show "ON-LINE:READY".	Printer and circuit cards are correctly installed.
Interface cable fails to connect.	Interface cable and connectors.
Paper feed problem.	Paper path for obstruction. Forms tractor for correct side to side settings.
Printing is light.	Ribbon, replace if worn. Paper thickness lever setting (manual version only).
Printed characters have voids or vary in darkness.	Paper, ribbon and platen. Paper thickness lever setting (manual version only).
Poor print quality.	Paper thickness lever setting (manual version only) and ribbon cassette.
Will not print.	If a "PAPER OUT ERROR" is displayed, check the paper path and sensor. Ensure the ribbon is correctly installed between the print head and platen. Also check the interface cable.
Incorrect character printed.	Host system control or data code may not agree with the printer's features (MENU and HARDWARE) selections, see Section 3.

**Table 4-1 – continued**

Symptom	Check
Ribbon breaks, or jam.	Installation of ribbon and paper thickness lever setting (manual version only).
Extra line feed, or no line feed.	Setup of "LF CODE" or "CR CODE". See Section 3.
Paper jam.	Turn the power switch off, push the paper path lever towards rear of printer, and carefully pull the paper out of the paper path.

**Printer  
Care**

## 4.6 REPACKING YOUR PRINTER

Use the carton and packing material supplied with the printer if you have to store or transport your printer.

Turn computer and printer power off.

Disconnect the interface cable.

Remove the power cord, paper guide, platen knobs and ribbon cassette. Place these items into their protective plastic bags and position them inside the tray of the shipping carton.

Clean the printer, if required.

Refer to paragraph 1-3. Set the paper path lever towards the front position of the printer. Position the print head at the left end of the print line. Install the shipping restraints and ties to prevent the print head, ribbon platform, and paper bail from moving during transport.

Close and tape the printer's covers.

Put the printer into its protective plastic bag.

Install the polystyrol pads on each side of the printer and slide it into the shipping carton.

Slide the accessory tray into the shipping carton.

Close the flaps on the shipping carton.

Secure the shipping carton with the two plastic handles to complete the packing procedure.



## SECTION 5

# COMMAND SETS

### 5.1 OUTLINE

This section provides an overview of your printer's command set. It may not provide the command details and programming examples necessary for modifying your software packages or writing your own programs. They are given in the following publications:

"PROGRAMMER'S MANUAL (DPL24C Emulation Type)"

"PROGRAMMER'S MANUAL (DPL24D Emulation Type)"

If you want to get these publications, contact your dealer.

This printer can use three types of command sets and emulate several models of printers.

**For the DPL24C emulation type:**

EMULATE	PRINTER
DPL24C	FUJITSU DPL24C color printer
DPL24I	FUJITSU DPL24 type I printer
IBM GPH	IBM Graphic printer
FX-80	EPSON FX-80 printer
JX-80	EPSON JX-80 printer

**For the DPL24D emulation type:**

EMULATE	PRINTER
DPL24D	FUJITSU DPL24 type D printer
DIABLO	DIABLO 630 API printer

**For the IBM Proprinter XL emulation type:**

EMULATE	PRINTER
IBM-PRO	IBM Proprinter XL

The next three sections list the set (select or execute) and reset conditions of the functions of command codes (control characters and ESC sequences) for the DPL24C, DPL24D and IBM-PRO emulation modes. These command codes are classified into eleven categories according to the Programmer's Manual.

**NOTE:**

Values m and n in the tables in this section are written in decimal notation. These values can also be written in hexadecimal notation.

## 5.2 DPL24C EMULATION

This section lists the command codes used for the FUJITSU DPL24C, DPL24 type I, IBM Graphics, and EPSON FX-80, FX-100 and JX-80 printers.

**(1) Print mode control**

These commands control the size, thickness, style, spacing, and underlining of characters for emphasis readability.

Function	Command	
	Set	Reset
Double-width mode (effective for one line)	SO or ESC SO	DC4, CR ESC !(n) ESC W(0) LF FF ESC LF ESC J(n) ESC j(n) VT ESC VT(n)
Double-width mode	ESC W(1)	ESC W(0) ESC !(n)
Double-height mode	ESC V 1	ESC V 0
Condensed mode	SI or ESC SI	DC2 ESC !(n)
Underline mode	ESC-(1)	ESC-(0) ESC x
Shadow print mode	ESC E	ESC F ESC x
Bold print mode	ESC G	ESC H ESC x
Italic print mode	ESC 4	ESC 5
Superscript mode	ESC S(0)	ESC T
Subscript mode	ESC S(1)	ESC T
Proportional spacing mode	ESC p(1)	ESC p(0)
Various print modes (*1)	ESC !(n)	ESC !(n)

Available for all DPL24C emulations.

\*1 Bit assignment of value in ESC !(n)

Bit	Print mode
7	Not assigned (don't care)
6	Proportional spacing (when 1)
5	Double-width (when 1)
4	Bold (when 1)
3	Shadow (when 1)
2	Condensed (when 1)
1	Not assigned (don't care)
0	Elite (when 1) or pica (when 0) pitch

## (2) Horizontal movement control

These commands control the movement and position of the carriage. These commands also set spacing in units of 1/120 or 1/180 inch.

### Motion commands

Function	Command
Space	SP
Backspace (*1)	BS
Carriage return	CR

Available for all DPL24C emulations.

\*1 In the bit image graphics mode, the carriage returns to the image graphics start position on the line.

**Spacing change commands**

Function	Command
Set elite pitch	ESC M
Set pica pitch	ESC P
Set horizontal spacing to (n-1)/120 inch	ESC US(n) (1 ≤ n ≤ 127)
Set horizontal spacing to n/180 inch	ESC h(n) (0 ≤ n ≤ 255)
Character offset selection (± m/120 inch) (*1)	ESC DC1 (n) (0 ≤ n ≤ 127)

Available for all DPL24C emulations.

\*1 m is the value of n excluding bit 6, and indicates plus when 0. The offset is reset by CR or ESC x.

**(3) Vertical movement control**

These commands control the movement and position of the paper. These commands also set spacing in units of 1/180 or 1/60 inch.

**Motion commands**

Function	Emulation			Command
	DPL24C DPL24I	IBM GPH	FX 80 JX 80	
Line feed	✓	✓	✓	LF
Negative line feed	✓	✓	✓	ESC LF
Form feed	✓	✓	✓	FF
Single line feed (n/180 inch)	✓			ESC J(n) (0 ≤ n ≤ 255)
Single line feed (n/216 inch)		✓	✓	
Single line feed backward (n/180 inch)	✓			ESC j(n) (0 ≤ n ≤ 255)
Single line feed backward (n/216 inch)		✓	✓	

Command Sets

### Spacing change commands

Function	Emulation			Command
	DPL24C DPL24I	IBM GPH	FX 80 JX 80	
Set line spacing to 1/8 inch	✓	✓	✓	ESC 0
Set line spacing to 7/60 inch 7/72 inch	✓	✓	✓	ESC 1
Set line spacing to n/180 inch n/216 inch	✓	✓	✓	ESC 3(n) (0 ≤ n ≤ 256)
Preset line spacing to n/60 inch n/72 inch	✓ (*1)	✓	✓	ESC A(n) (0 ≤ n ≤ 127)
Set line spacing to n/60 inch n/72 inch	✓ (*2)		✓	ESC A(n) (0 ≤ n ≤ 127)
Set line spacing to the value preset	✓ (*1)	✓		ESC 2
Set line spacing to 1/6 inch	✓ (*2)		✓	ESC 2

\*1 These 2 commands are effective only when the "GRPH LF:" setting of the printer's display is "IBM GPH"

\*2 These 2 commands are effective only when the "GRPH LF:" setting of the printer's display is "FX-80"

### (4) Tabbg

Tabbing consists of two types -- horizontal tabbing and vertical tabbing. Both types of tabbing have two methods. One is normal tabbing, in which the carriage or paper is moved sequentially to preset tab stops on command. The other is absolute tabbing, in which the carriage or paper is moved in either direction directly to any of 255 possible positions from any other position. In addition, in horizontal tabbing, the next print character start position can be specified in units of 1/360 inch.

#### Horizontal

Function	Command
Set horizontal tab positions to columns n1, ..., nk	ESC D(n1) ... (nk)NUL (1 ≤ nk ≤ 255) (nk-1 < nk) (1 ≤ k ≤ 160)
Reset all horizontal tabs	ESC D NUL
Horizontal tab execution	HT
Absolute horizontal tab execution (to column n)	ESC HT(n) (1 ≤ n ≤ 255)
Absolute print position (m/360 inch) (*1)	ESC \$(n1)(n2) (0 ≤ m ≤ 4895)

Available for all DPL24C emulations.

\*1  $m = 256 \times n2 + n1$

**Vertical**

Function	Command
Set vertical tab positions to lines $n_1, \dots, n_k$	ESC B(n1) ... (nk)NUL ( $0 \leq n_k \leq 254$ ) ( $n_k - 1 < n_k$ ) ( $1 \leq k \leq 64$ )
Reset all vertical tabs	ESC B NUL
Vertical tab execution	VT
Absolute vertical tab execution (line $n$ )	ESC VT(n) ( $1 \leq n \leq 255$ )

Available for all DPL24C emulations.

**(5) Page formatting**

These commands set the right and left margins based on the current setting of character spacing, set the page length in lines, and cause the printer to skip a specified number of lines on a page.

Function	Command
Set right margin (column $n$ )	ESC Q(n) ( $1 \leq n \leq 255$ )
Set left margin (column $n$ )	ESC l(n) ( $0 \leq n \leq 255$ )
Set skip perforations ( $n$ lines)	ESC N(n) ( $1 \leq n \leq 127$ )
Reset skip perforations	ESC O
Set page length in lines ( $n$ lines)	ESC C(n) ESC FF(n) ( $1 \leq n \leq 127$ )
Set page length in inches ( $n$ inches)	ESC C NUL(n) ESC FF NUL(n) ( $1 \leq n \leq 22$ )

Available for all DPL24C emulations.



**(6) Miscellaneous****Input data control**

Function	Command
Select character set 1	ESC 7
Select character set 2	ESC 6
Select international character (*1)	ESC R(n) ( $0 \leq n \leq 7$ )
Cancel line buffer	CAN
Select printer	DC1
Deselect printer	DC3
Force MSB to 1	ESC >
Force MSB to 0	ESC =
Cancel MSB control	ESC #

Available for all DPL24C emulations.

\*1 Value n and language

n	Language
0	American English
1	French
2	German
3	British English
4	Danish/Norwegian
5	Swedish/Finnish
6	Italian
7	Spanish

**Others**

Function	Command
Select print color (*1) (seven colors)	ESC r(n) ( $0 \leq n \leq 6$ )
Bell	BEL
Enable paper end sensor	ESC 9
Disable paper end sensor	ESC 8
Set typewriter mode	ESC i(1)
Reset typewriter mode	ESC i(0)
Remote reset	ESC @ ESC CR P
Set head to home	ESC <
Set unidirectional printing	ESC U(1)
Set bidirectional printing	ESC U(0)

Available for all DPL24C emulations.

\*1 Value and color

n	Color
0	Black
1	Magenta
2	Cyan
3	Violet
4	Yellow
5	Orange
6	Green

## (7) Word processing

This command aligns the right margins of the text.

Function	Command
Set auto justify mode	ESC m
Reset auto justify mode	ESC x

Available for all DPL24C emulations.

## (8) Font control and downloading

The Font Select command selects a font from the resident ROM, the download RAM, and the optional font cartridge. The Font Copy and Download commands enable the user to replace part of the currently used font with a custom-made character font.

Function	Command
Font select (*1)	ESC %(m)(n)
Font copy (*2)	ESC : NUL(m)(n)
Download (*3)	ESC & (m)(Cs)(Ce)(Data)

Available for all DPL24C emulations.

\*1 Font select

$$m = m1 + m2$$

m1	ROM/RAM to be selected
0	Resident ROM
1	Download RAM
2	Font card
3	Download RAM (same as 1)

m2	Horizontal dot density to be used
0	Font-determined density
4	360 dots/inch (letter quality)
8	180 dots/inch (correspondence quality)
12	120 dots/inch (draft quality)

n	Font selection
0	Font 0 (COURIER 10 for resident ROM)
1	Font 1 (PRESTIGE ELITE 12 for resident ROM)
2	Font 2 (DRAFT for resident ROM)
3	Font 3 (COMPRESSION for resident ROM)
4	Font 4 (BOLDFACE PS for resident ROM)
5	Font 5
6	Font 6
7	Font 7

## \*2 Font copy

m	Source font (resident ROM)
0	Font 0 (COURIER 10)
1	Font 1 (PRESTIGE ELITE 12)
2	Font 2 (DRAFT)
3	Font 3 (COMPRESSION)
4	Font 4 (BOLDFACE PS)
5	Font 5
6	Font 6
7	Font 7

n	Destination font (download RAM)
0	Font 0
1	Font 1

\*3 Download

m = m1 + m2

m1	Font location (download RAM)
0	Font 0
1	Font 1

m2	Horizontal dot density to be used
16	360 dots/inch (letter quality)
32	180 dots/inch (correspondence quality)
48	120 dots/inch (draft quality)

Cs: ASCII code of starting download character

Ce: ASCII code of ending download character

⌒Data: Repetition of image data with column width value for each character

(9) Bit image graphics control

The printer can print characters and pictures as a collection of dots. This is called bit image printing, and the commands which specify bit image printing are called bit image commands. There are two image modes: 24-dot and 8-dot. In the 24-dot image mode, an image element consists of 24 dots, and a dot is printed with one pin. In the 8-dot image mode, an image element consists of 8 dots, and a dot is printed with three pins. The print head size of the printer is 1.2 times larger than that of the IBM Graphics printer. Therefore, the size of the images printed by the printer is 1.2 times larger than for the IBM Graphics printer.

In 8-dot image printing, the horizontal and vertical dot densities for all modes under DPL24C/DPL24I emulation are different from those under IBM GPH/FX-80/JX-80 emulation, except for the CRT graphics II mode. Graphic images printed under DPL24C/DPL24I emulation are 1.2 times larger than those printed under IBM GPH/FX-80/JX-80 emulation. Please choose the most suitable emulation.

Function	Horizontal dot density (dots/inch)	Vertical dot density (dots/inch)	Number of vertical dots	Emulation		Command
				DPL24C DPL24I	IBM GPH FX-80 JX-80	
Single density image	50	60	8	✓		ESC K (n2) (data) (*1)
	60	72	8		✓	
Double density image	100	60	8	✓		ESC L (n1) (n2) (data)
	120	72	8		✓	
Double speed Double density image	100	60	8	✓		ESC Y (n1) (n2) (data)
	120	72	8		✓	
Quadruple density	200	60	8	✓		ESC Z (n1) (n2) (data)
	240	72	8		✓	
Various image modes (*2)	50 - 360	60, 72, 180	8, 24	-	-	ESC * (m) (n1) (n2) (data)

**Notes:**

\*1 (n1) & (n2) are regarded as  $n = n1 * 256 + n2$  which stands for the number of data columns of the (data) next to them. And the following relations are given:

$n = n1 * 256 + n2 =$  Number of data columns = Number of data bytes (when 8-dot image)

$n = n1 * 256 + n2 =$  Number of data columns = (Number of data bytes)/3 (when 24-dot image)

\*2 For the each mode of the image see the next table.

Various image modes of ESC \* (m) (n1) (n2) (data) command

Function	Horizontal dot density (dots/inch)	Vertical dot density (dots/inch)	Number of vertical dots	Emulation		Value (m) is ESC * (m) (n1) (n2) (data) command (decimal)
				DPL24C DPL24I	IBM GPH FX-80 JX-80	
Single density image	50	60	8	✓		0
	60	72	8		✓	
Double density image	100	60	8	✓		1
	120	72	8		✓	
Double speed double density image	100	60	8	✓		2
	120	72	8		✓	
Quadruple density	200	60	8	✓		3
	240	72	8		✓	
CRT graphics I	67	60	8	✓		4
	80	72	8		✓	
Plotter image	60	60	8	✓		5
	72	72	8		✓	
CRT graphics II	90	60	8	✓	✓	6
Normal-density image	60	180	24	✓	✓	32
Double-density image	120	180	24	✓	✓	33
CRT II	90	180	24	✓	✓	38
Triple-density	180	180	24	✓	✓	39
Quadruple density	360	180	24	✓	✓	40

Command Sets

## (10) Cut sheet feeder control

The ESC and non-ESC sequence commands control the cut sheet feeder. The ESC sequence command selects the bin and feeds paper immediately. The non-ESC sequence command only selects the bin, feed operation depends on the subsequent feed command.

Function	Command
Feed from bin 1	ESC EM 1
Feed from bin 2	ESC EM 2
Feed from bin 3	ESC EM E
Remove paper (eject)	ESC EM R
Select bin 1 (*1)	//1//
Select bin 2 (*1)	//2//
Select bin 3 (*1)	//E//
Select remove (eject) (*1)	//R//
Select change bins (*1)	//C//

Available for all DPL24C emulations.

\*1 These select commands must begin and end with a CR or LF command.

## (11) Reset and sense control

This command forcibly resets the printer regardless of its state. When the printer receives this command, it immediately executes the command without queuing it in the buffer.

Function	Command
Printer initialize	ESC SUB I

Available for all DPL24C emulations.



## 5.3 DPL24D EMULATION

This section lists the command codes used for the FUJITSU DPL24 type and DIABLO 630 API printers.

### (1) Print mode control

These commands control the size, thickness, style, spacing, and underlining of characters for emphasis and readability.

Function	Command	
	Set	Reset
Double-width mode	ESC w(1)	ESC w(0)
Underline mode	ESC E	ESC R ESC X
Shadow print mode	ESC W	ESC & ESC X CR
Bold print mode	ESC O	ESC & ESC X CR
Proportional spacing mode	ESC P	ESC Q

### (2) Horizontal movement control

These commands control the movement and position of the carriage. These commands also set spacing in units of 1/120 or 1/180 inch.

#### Motion commands

Function	Command
Space	SP
Backspace (*1)	BS
Backspace 1/120 inch	ESC BS
Carriage return	CR

\*1 In the bit image graphics mode, the carriage returns to the image graphics start position on the line.

### Spacing change commands

Function	Command
Set horizontal spacing to (n-1)/120 inch	ESC US(n) (1 ≤ n ≤ 126)
Set horizontal spacing to n/180 inch	ESC b(n) (0 ≤ n ≤ 255)
Set horizontal spacing to the value set by control panel	ESC S
Character offset selection (± m/120 inch) (*1)	ESC DC1(n) (1 ≤ n ≤ 126)

\*1 m is the value of n excluding bit 6, and indicates plus when 0.  
The offset is reset by CR or ESC X.

### (3) Vertical movement control

These commands control the movement and position of paper. These commands also set spacing in units of 1/180 or 1/60 inch.

#### Motion commands

Function	Command
Line feed	LF
Negative line feed	ESC LF
Form feed	FF
Single line feed (n/180 inch)	ESC J(n) (0 ≤ n ≤ 255)
Single line feed backward (n/180 inch)	ESC j(n) (0 ≤ n ≤ 255)
Half line feed	ESC U
Negative half line feed	ESC D
Line spacing according to bit image mode	ESC v

**Spacing change commands**

Function	Command
Set line spacing to n/180 inch	ESC a(n) (0 ≤ n ≤ 255)
Set line spacing to (n-1)/48 inch	ESC RS(n) (1 ≤ n ≤ 126)

**(4) Tabbing**

Tabbing consists of two types -- horizontal tabbing and vertical tabbing. Both types of tabbing have two methods. One is normal tabbing, in which the carriage or paper is moved sequentially to preset tab stops on command. The other is absolute tabbing, in which the carriage or paper is moved in either direction directly to any of 255 possible positions from any other position. In addition, in horizontal tabbing, the next print character start position can be specified in units of 1/360 inch.

**Horizontal**

Function	Command
Horizontal tab execution	HT
Absolute horizontal tab execution (column n)	ESC HT(n) (1 ≤ n ≤ 255)
Set horizontal tab stop (at current position)	ESC 1
Reset horizontal tab stop (at current position)	ESC 8
Reset all horizontal tabs	ESC 2
Absolute print position (m/360 inch) (*1)	ESC \$(n2)(n1) (0 ≤ m ≤ 4895)

\*1 m = 256 x n2 + n1

Command Sets

**Vertical**

Function	Command
Vertical tab execution	VT
Absolute vertical tab execution (line n)	ESC VT(n) ( $1 \leq n \leq 255$ )
Set vertical tab stop (at current position)	ESC -
Reset all vertical tabs	ESC 2

**(5) Page formatting**

These commands set the right, left, top, and bottom margins based on the current setting of character and line spacing and set the page length in lines.

Function	Command
Set right margin	ESC 0
Set left margin	ESC 9
Set page length in lines (n lines)	ESC FF(n) ( $1 \leq n \leq 126$ )
Set top margin	ESC T
Set bottom margin	ESC L
Reset top & bottom margins	ESC C

**(6) Miscellaneous****Input data control**

Function	Command
Select international character (*1)	ESC "(n) (0 ≤ n ≤ 7)
Select printer	DC1
Deselect printer	DC3
Print suppression (*2)	ESC 7
Select primary character set	SI
Select supplementary character set	SO
Print '€' character	ESC Y
Print '□' character	ESC Z

\*1 Value n and language

n	Language
0	American English
1	British English
2	German
3	French
4	Italian
5	Spanish
6	Swedish/Finnish
7	Danish/Norwegian

\*2 The print suppression mode is reset by CR.

**Others**

Function	Command
Select print color (*1) (seven colors)	ESC r(n) ( $0 \leq n \leq 6$ )
Select black ribbon	ESC B
Select magenta ribbon	ESC A
Bell	BEL
Set backward print mode	ESC 6
Set forward print mode	ESC 5 CR
Set graphics mode (in 1/60 inches)	ESC 3
Reset graphics mode	ESC 4 CR
Set auto carriage return mode	ESC ?
Reset auto carriage return mode	ESC !
Set unidirectional printing	ESC \
Set bidirectional printing	ESC /
Remote reset	ESC CR P

\*1 Value and color

n	Color
0	Black
1	Magenta
2	Cyan
3	Violet
4	Yellow
5	Orange
6	Green

### (7) Word processing

These commands align the right margins of the text and center the text between the right and left margins.



Function	Command
Set auto justify mode	ESC M
Set auto center mode (*1)	ESC =
Reset auto justify & center mode	ESC X

\*1 The auto center mode is also reset by CR or LF.

### (8) Font control and downloading

The Font Select command selects a font from the resident ROM, the download RAM, and the optional font cartridge. The Font Copy and Download commands enable the user to replace part of the currently used font with a custom-made character font.



Function	Command
Font select (*1)	ESC # (n)
Font select (*2)	ESC : NUL(m)(n)
Download (*3)	ESC ℓ(m)(Cs)(Ce)(Data)

\*1 Font select

$$n1 + n2 + n3$$



n1	Font selection
0	Font 0 (COURIER 10 for resident ROM)
1	Font 1 (PRESTIGE ELITE 12 for resident ROM)
2	Font 2 (BOLDFACE PS for resident ROM)
3	Font 3 ([COURIER 10] for resident ROM)
4	Font 4 (DRAFT for resident ROM)
5	Font 5 (COMPRESSION for resident ROM)
6	Font 6 ([COURIER 10] for resident ROM)
7	Font 7 ([COURIER 10] for resident ROM)

Command Sets

n2	Density selection
16	360 dots/inch (letter quality)
32	180 dots/inch (correspondence quality)
48	120 dots/inch (draft quality)

n3	ROM/RAM selection
0	Resident ROM
64	Font cartridge ROM
192	Download RAM

## \*2 Font copy

m	Destination font (download RAM)
192	Font 0
193	Font 1

n	Source font (resident ROM)
0	Font 0 (COURIER 10)
1	Font 1 (PRESTIGE ELITE 12)
2	Font 2 (BOLDFACE PS)
3	Font 3 ([COURIER 10])
4	Font 4 (DRAFT)
5	Font 5 (COMPRESSION)
6	Font 6 ([COURIER 10])
7	Font 7 ([COURIER 10])



\*3 Download

$$m = m1 + m2$$

m1	Font location (download RAM)
0	Font 0
1	Font 1

m2	Horizontal dot density to be used
208	360 dots/inch (letter quality)
224	180 dots/inch (correspondence quality)
240	120 dots/inch (draft quality)

Cs: ASCII code of starting download character

Ce: ASCII code of ending download character

Data: Repetition of image data with column width number for each character

**(9) Bit image graphics control**

The printer can print characters and pictures as a collection of dots. This is called bit image printing, and the commands which specify bit image printing are called bit image commands. There is one image mode: 24-dot. In the 24-dot image mode, an image element has 24 dots, and each dot is printed with one pin.

Function	Command
Set 8-dot image mode with various dot densities (*1)	ESC *(m)(n1)(n2)(Data)
Set 24-dot image mode	ESC H(n1)(n2)(Data)

**Note:**

$j6 \times n2 + n1$  indicates the last column of image data. (The last column must not exceed the last print character start position on the line.)

\*1 Dot density set by m (8-dot image)

m (Dec)	Horizontal dot density (dots/inch)	Vertical dot density (dots/inch)	Line spacing (by ESC v)
0	60	60	24/180 inch
1	90	90	16/180 inch
2	180	180	8/180 inch
4	200/3	60	24/180 inch

## (10) Cut sheet feeder control

The ESC and non-ESC sequence commands control the cut sheet feeder. The ESC sequence command selects the bin and feeds paper immediately. The non-ESC sequence command only selects the bin; feed operation depends on the subsequent feed command.

Function	Command
Feed from bin 1	ESC EM 1 ESC I
Feed from bin 2	ESC EM 2 ESC K
Feed from bin 3	ESC EM E
Remove paper (eject)	ESC EM R
Select bin 1 (*1)	//1//
Select bin 2 (*1)	//2//
Select bin 3 (*1)	//E//
Select remove (eject) (*1)	//R//
Select change bins (*1)	//C//

\*1 These select commands must begin and end with a CR or LF command.

## (11) Reset and sense control

These commands forcibly reset the printer regardless of its state. When the printer receives this command, it immediately executes the command without queueing it in the buffer.

Function	Command
Printer initialize	ESC SUB I
Error Reset	ESC SUB R
Request status byte 1	ESC SUB 1
Request status byte 3	ESC SUB 3
Memory test	ESC SUB SO

## 5.4 IBM-PRO EMULATION

This section lists the command codes used for the IBM Proprinter XL.

### (1) Print mode control

These commands control the size, thickness, style, spacing, and underlining of characters for emphasis readability.

Function	Command	
	Set	Reset
Double-width mode (effective for one line)	SO or ESC SO	DC4, CR ESC W(0) LF FF ESC J(n) ESC j(n) VT ESC VT(n)
Double-width mode	ESC W(1)	ESC W(0)
Double-height, double-width, and double-line feed mode	ESC [ @(n1)(n2)(m1)...(m4)	
Condensed mode	SI or ESC SI	DC2
Underline mode	ESC -(1)	ESC -(0)
Overline mode	ESC _(1)	ESC _(0)
Shadow print mode	ESC E	ESC F
Bold print mode	ESC G	ESC H
Superscript mode	ESC S(0)	ESC T
Subscript mode	ESC S(1)	ESC T
Proportional spacing mode	ESC P(1)	ESC P(0)

\*1 Bit assignment of values n and m in ESC [ @

n1 and n2 specify the number of the succeeding bytes.

- n1: Low order byte, normally 4.
- n2: High order byte, normally 0.

m1 to m4 specify the three modes.

- m1: Reserved, must be 0 (NUL).
- m2: Reserved, must be 0 (NUL).
- m3: Line spacing and character height modes.

Bit	Mode
5	Double line feed
4	Normal line feed
1	Double height character
0	Normal height character

m4: Character width mode.

Bit	Mode
1	Double width character
0	Normal width character

When both bits are not specified for a mode, that mode is left unchanged.

## (2) Horizontal movement control

These commands control the movement and position of the carriage. These commands also set spacing in units of 1/120 or 1/180 inch.

### Motion commands

Function	Command
Space	SP
Backspace (*1)	BS
Carriage return	CR

\*1 In the bit image graphics mode, the carriage returns to the image graphics start position on the line.

### Spacing change commands

Function	Command
Set elite pitch	ESC :
Set pica pitch	DC2

## (3) Vertical movement control

These commands control the movement and position of the paper. These commands also set spacing in units of 1/216 or 1/72 inch.

### Motion commands

Function	Command
Line feed	LF
Form feed	FF
Single line feed (n/216 inch)	ESC J(n) (1 ≤ n ≤ 255)

**Spacing change commands**

Function	Command
Set line spacing to 1/8 inch	ESC 0
Set line spacing to 7/72 inch	ESC 1
Set line spacing to $n/216$ inch (graphic line spacing)	ESC 3(n) ( $1 \leq n \leq 255$ )
Set line spacing to $n/72$ inch (text line spacing) (*1)	ESC A (n) ( $0 \leq n \leq 127$ )
Enable text line spacing	ESC 2

- \*1 The text line spacing value is set independently of other line spacing settings but is made effective after the ESC 2 command.

**(4) Tabbing**

Tabbing consists of two types -- horizontal tabbing and vertical tabbing; the carriage or paper is moved sequentially to preset tab stops on mand.

**Horizontal**

Function	Command
Set horizontal tabs to columns $n_1, \dots, n_k$	ESC D(n1) ... (nk)NUL ( $1 \leq n_k \leq 255$ ) ( $n_k - 1 < n_k$ ) ( $1 \leq k \leq 256$ )
Reset all horizontal tabs	ESC D NUL
Reset tabs to defaulted values	ESC R
Horizontal tab execution	HT

**Vertical**

Function	Command
Set vertical tabs to lines n1, ..., nk	ESC B(n1) ... (nk)NUL ( $0 \leq n_k \leq 254$ ) ( $n_k - 1 < n_k$ ) ( $1 \leq k \leq 127$ )
Reset all vertical tabs Vertical tab execution	ESC B NUL VT

**(5) Page formatting**

These commands set the right and left margins based on the current setting of character spacing, set the page length in lines, and cause the printer to skip a specified number of lines on a page.

Function	Command
Set left and right margins (columns n and m) (*1)	ESC X(n)(m) ( $0 \leq n \leq 255$ ) ( $1 \leq m \leq 255$ )
Set perforation skip (n lines)	ESC N(n) ( $1 \leq n \leq 127$ )
Reset perforation skip	ESC O
Set page length in lines (n lines)	ESC C(n) ( $1 \leq n \leq 127$ )
Set page length in inches (n inches)	ESC C NUL(n) ( $1 \leq n \leq 22$ )
Set top of form	ESC 4

\*1 n specifies the left margin and m the right margin.



**(6) Miscellaneous****Input data control**

Function	Command
Select character set 2	ESC 6
Select character set 1	ESC 7
Cancel line buffer	CAN
Select printer	DC1
Deselect printer	ESC Q SYN
Select a character from all character set and print it repeatedly (*1)	ESC \ (n1)(n2)(char)
Select and print a character from all character set	ESC ^ (char)

\*1 n1 and n2 specify the number of characters to be printed from the all characters set.

$$\text{Total} = n1 + 256 \times n2$$

**Others**

Function	Command
Select print color (*1) (seven colors)	ESC r(n) ( $0 \leq n \leq 6$ )
Bell	BEL
Auto LF with CR code	ESC 5(1)
No LF with CR code	ESC 5(0)
Bidirectional printing	ESC U(0)
Unidirectional printing	ESC U(1)

## \*1 Value and color

n	Color
0	Black
1	Magenta
2	Cyan
3	Violet
4	Yellow
5	Orange
6	Green

**(7) Font select and downloading**

The Font Select command selects a font from the resident ROM, the download RAM, and the optional font card. The Download command enables the user to replace part of the currently used font with a custom-made character font.

Function	Command
Font and print quality select (*1)	ESC I(n)
Download (*2)	ESC =(C1)(C2)DC4(Cs)(Data)

## \*1 Font and print quality select

n	Font and print quality
0	Resident font, letter quality
2	Resident font, bold letter quality
4	Downloaded font, draft quality
6	Downloaded font, bold draft quality

The resident font is the currently selected one.

## \*2 Download

C1 and C2: The number of bytes that follow  
 $C2 (N = C1 + 256 \times C2)$

C4: Decimal 20 or hexadecimal 14

Cs: ASCII code of starting download character

Data: Repetition of character matrix data (11 bytes) preceded by the attribute (2 bytes) for each character

Attribute is as follows:

First byte bit 7; ON for descending character

OFF for ascending character

Second byte; Ignored

## (8) Bit image graphics control

The printer can print characters and pictures as a collection of dots. This is called bit image printing, and the commands which specify bit image printing are called bit image commands. An image element consists of 8 dots, and a dot is printed with three pins (two out of three pins, to be exact). The print head size of the printer is 1.2 times larger than that of the IBM Proprinter XL, but the size of the images printed by the printer is exactly the same with that of the IBM Proprinter XL.

Function	Horizontal dot density (dots/inch)	Vertical dot density (dots/inch)	Number of vertical dots	Command (*1)
Single density image	60	72	8	ESC K (n1) (n2) (data)
Double density image	120	72	8	ESC L (n1) (n2) (data)
Double speed double density image	120	72	8	ESC Y (n1) (n2) (data)
Quadruple density	240	72	8	ESC Z (n1) (n2) (data)

\*1 (n1) & (n2) are regarded as  $n = n1 * 256 + n2$  which stands for the number of data columns of the (data) next to them. And the following relations are given:

$$n = n1 * 256 + n2 = \text{Number of data columns} = \text{Number of data bytes}$$

## (9) Cut sheet feeder control

The ESC and non-ESC sequence commands control the cut sheet feeder. The ESC sequence command selects the bin and feeds paper immediately. The non-ESC sequence command only selects the bin; feed operation depends on the subsequent feed command.

Function	Command
Feed from bin 1	ESC EM 1
Feed from bin 2	ESC EM 2
Feed from bin 3	ESC EM E
Remove paper (eject)	ESC EM R
Select bin 1 (*1)	//1//
Select bin 2 (*1)	//2//
Select bin 3 (*1)	//E//
Select remove (eject) (*1)	//R//
Select change bins (*1)	//C//

\*1 These select commands must begin and end with a CR or LF command.

# APPENDIX A

## CUT SHEET FEEDERS

### SUPPORTED MODELS

The printer can be equipped with the following cut sheet feeder models.

SF231

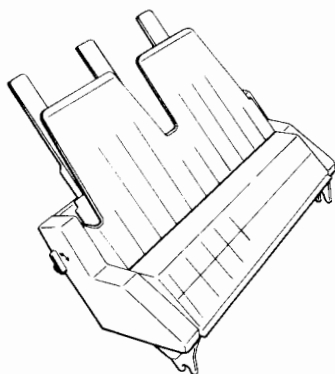

ASF300

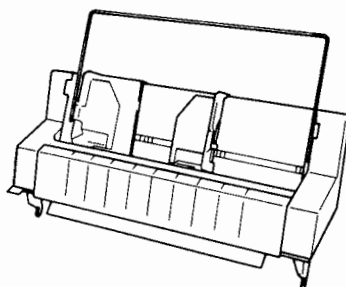

Büro und Datentechnik (BDT) produces the ASF300 and add-on adapter. Fujitsu produces the SF231 and its add-on adapters for expanding bins. For types and model numbers, see "SUPPLIES, OPTIONS, AND PUBLICATIONS".

Consult the manual shipped with the cut sheet feeder and your authorized dealer for specifications and additional performance data on these cut sheet feeders.

### CUT SHEET FEEDER INSTALLATION

Prepare the printer for the cut sheet feeder as follows:

Confirm printer power is off.

Open the front cover.

Lift and remove the top cover.

Move the paper path lever towards the rear of the printer.

Pull the paper bail lever forward (away from the platen).

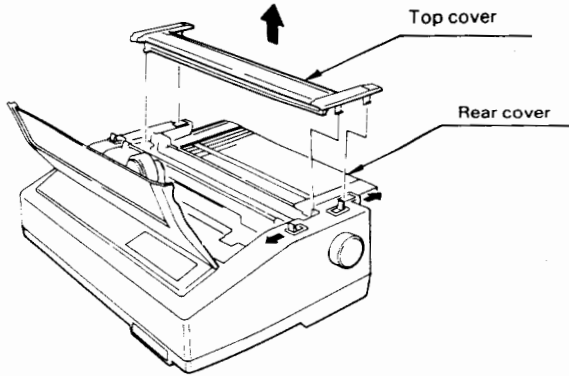

**Figure A-1 Preparing the printer**

Place the cut sheet feeder on the printer as shown in Figure A-2.

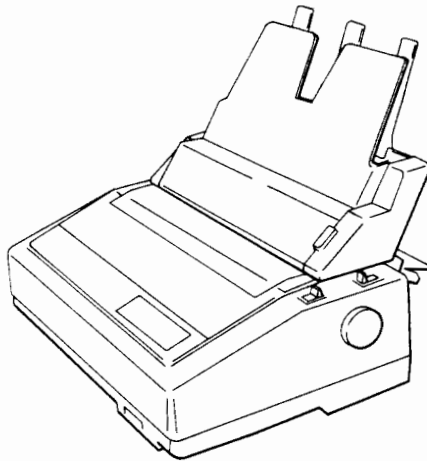

**Figure A-2 Mounting the cut sheet feeder**

For a functional check of the cut sheet feeder, turn the printer's platen knob manually, in the forward direction. The Cut Sheet Feeder's eject rollers should rotate.

Connect the cable from the cut sheet feeder into the printer's cut sheet feeder connector as follows.

Confirm power is off.

Ensure the pins in the cable's connector match the holes in the printer's cut sheet feeder connector.

Insert the cable connectors as shown in Figure A-3.

Confirm that the cable connectors match up with the connector receptacles on the printer and cut sheet feeder.

Insert the connectors and confirm their orientation mark (projection). Also connect the grounding plugs.

Clamp the cut sheet feeder cable in place using the interface cable clamps.

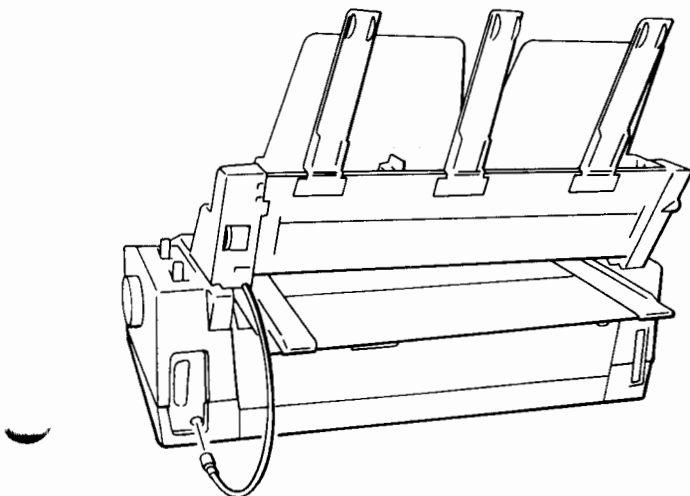

**Figure A-3** Connecting the cut sheet feeder cable

## SET FORM (PAGE) LENGTH

Use the control panel to select the correct page length when the printer is in setup mode (PAGE LG is defined in Section 3).

Use a system control command to set form length when the printer is online (as defined in your software manual or the Programmer's Manual of the printer).

Form length must correspond to the length of paper used in the cut sheet feeder.

## LOAD PAPER

Manually insert paper into the sheet feeder's bin(s).

Paper must be manually fanned before placing it into a sheet feeder's paper bin.

Paper will be loaded into the printer when:

- The printer receives a printable character code.
- A feed control command is received from the system.
- With the RESET switch held down, paper will be loaded to the top of form when the LOAD/(FF) button on the control panel is pressed.

### NOTES:

For the SF23x or ASF300, you can load a sheet that is a trial sheet or that has a different size from sheets in use with the sheet feeder installed. To do so, put a sheet in the forms inlet and press the FF switch while holding down the RESET switch. A feed command is not necessary.



## PAPER EJECT

When the printer is online, a paper feed command from the system will cause the paper to eject.

When the printer is offline, paper will be ejected from the printer when the FF button on the control panel is pressed, until the paper is advanced out of the printer.

## PAPER OUT CONDITION

When a paper bin runs out of paper, a "PAPER OUT" message appears on the message display.

To resume printing:

Insert paper into the empty bin

Press the FF button on the control panel while holding down the RESET switch.

Paper will load and the "PAPER OUT" message will disappear.

Press the ONLINE button to continue printing.

## EXCHANGING RIBBON CASSETTE

The ribbon cassette cannot be exchanged with the cut sheet feeder installed. Therefore, you must demount the feeder and follow the ribbon exchanging procedure described in Section 2.1.

1. Turn off the printer power.
2. Disconnect the cut sheet feeder cable from the printer.
3. Demount the cut sheet feeder from the printer and place it on a level surface.
4. Exchange the ribbon cassette as explained in Section 2.
5. Reverse steps 1 to 3 to mount the cut sheet feeder.

—

—

—

## APPENDIX B

# RESIDENT AND CARD FONTS

In addition to the variety of fonts resident in your printer, you can use other fonts by using optional font cards.

Font cards allow you to use additional character fonts. All font cards are supplied in electrostatic proof cases. Handle your font cards with appropriate care.

### RESIDENT FONTS

There are five types of fonts resident in the printer.

- Courier 10
- Prestige Elite

Draft

- Compression
- Boldface PS

(1) Courier 10

L\H	0	1	2	3	4	5	6	7	8	9	A	B	C	D	E	F
	NUL	SOH	SP	0	@	P	~	p	Ç	É	Á	:	⊥	⊥	⊥	⊥
1	DC1	!	1	A	Q	a	ˆ	q	Û	É	á	:	⊥	⊥	⊥	⊥
2	DC2	"	2	B	R	b	ˆ	r	É	æ	í	:	⊥	⊥	⊥	⊥
3	♦	#	3	C	S	c	ˆ	s	Æ	ó	ú	:	⊥	⊥	⊥	⊥
4	♦	\$	4	D	T	d	ˆ	t	ô	ñ	Ñ	:	⊥	⊥	⊥	⊥
5	♦	%	5	E	U	e	ˆ	u	ö	ã	ã	:	⊥	⊥	⊥	⊥
6	♦	&	6	F	V	f	ˆ	v	ò	ä	ä	:	⊥	⊥	⊥	⊥
7	BEL	'	7	G	W	g	ˆ	w	ó	å	å	:	⊥	⊥	⊥	⊥
8	BS	(	8	H	X	h	ˆ	x	ç	ê	ê	:	⊥	⊥	⊥	⊥
9	HT	)	9	I	Y	i	ˆ	y	ê	é	é	:	⊥	⊥	⊥	⊥
A	LF	*	A	J	Z	j	ˆ	z	ë	è	è	:	⊥	⊥	⊥	⊥
B	VT	+	B	K	[	k	ˆ	{	ï	ï	ï	:	⊥	⊥	⊥	⊥
C	FF	,	C	L	\	l	ˆ		ï	ï	ï	:	⊥	⊥	⊥	⊥
D	CR	-	D	M	^	m	ˆ	~	l	l	l	:	⊥	⊥	⊥	⊥
E	SO	.	E	N	ˆ	n	ˆ	ˆ	Å	Å	Å	:	⊥	⊥	⊥	⊥
F	SI	/	F	O	_	o	ˆ	ˆ	Å	Å	Å	:	⊥	⊥	⊥	⊥

## (2) Prestige Elite 12

0	1	2	3	4	5	6	7	8	9	A	B	C	D	E	F	SP
L\H	NUL	SP	0	@	P	~	p	Ç	É	À	Á	À	À	À	À	À
0	SOH	!	"	#	\$	%	&	'	(	)	*	+	,	-	.	/
1	DC1	"	#	DC3	DC4	§	SYN	ETB	CAN	EM	SUB	ESC	FS	GS	RS	US
2	STX			♦	♦	♦	♦	BEL	BS	HT	LF	VT	FF	CR	SO	SI
3																
4																
5																
6																
7																
8																
9																
A																
B																
C																
D																
E																
F																

## (3) Draft

L\H	0	1	2	3	4	5	6	7	8	9	A	B	C	D	E	F	SP
	NUL	SOH	STX	▼	◆	♣	◆	BEL	BS	HT	LF	VT	FF	CR	SO	SI	
	1	DLE	DC1	DC2	DC3	DC4	\$	SYN	ETB	CAN	EM	SUB	ESC	FS	GS	RS	US
	2	SP	!	"	#	\$	%	&	'	(	)	*	+	,	-	.	/
	3	0	1	2	3	4	5	6	7	8	9	:	;	<	=	>	?
	4	0	A	B	C	D	E	F	G	H	I	J	K	L	M	N	O
	5	P	Q	R	S	T	U	V	W	X	Y	Z	[	\	]	^	_
	6	'	a	b	c	d	e	f	g	h	i	j	k	l	m	n	o
	7	p	q	r	s	t	u	v	w	x	y	z	{		}	~	DEL
	8	ç	ü	é	à	ä	ã	á	ç	e	ë	è	ï	í	î	ï	A A
	9	É	æ	£	ó	ö	ó	ú	ú	y	ö	ü	ç	£	¥	R	f
	A	á	í	ó	ú	ñ	N	æ	ø	ó	í	í	í	í	í	í	« »
	B	☺	☹	☹	☹	☹	☹	☹	☹	☹	☹	☹	☹	☹	☹	☹	☹
	C	☹	☹	☹	☹	☹	☹	☹	☹	☹	☹	☹	☹	☹	☹	☹	☹
	D	☹	☹	☹	☹	☹	☹	☹	☹	☹	☹	☹	☹	☹	☹	☹	☹
	E	α	β	Γ	π	Σ	ο	μ	τ	φ	θ	Ω	δ	ε	ϕ	€	∩
	F	≡	±	λ	Σ		J	÷	≈	°	▪	•	√	n	²	■	SP

(4) Compression

L \ H	0	1	2	3	4	5	6	7	8	9	A	B	C	D	E	F	SP	
0	MUL	DLE	SP	!	"	#	\$	%	&	'	(	)	*	+	,	-	.	/
1	SOH	DC1	! "	DC3	DC4	\$	SYN	ETB	CAN	EM	SUB	ESC	FS	GS	RS	US		
2	STX	"	3	4	5	6	7	BEL	BS	HT	LF	VT	FF	CR	SO	SI		
3	v	4	5	6	7	8	9	:	;	<	=	>	?					
4	0	1	2	3	4	5	6	7	8	9	:	;	<	=	>	?	0	
5	P	Q	R	S	T	U	V	W	X	Y	Z	[	\	]	^	_		
6	.	a	b	c	d	e	f	g	h	i	j	k	l	m	n	o		
7	p	q	r	s	t	u	v	w	x	y	z	{		}	~	DEL		
8	ç	ü	é	â	ä	å	ß	ç	è	é	ê	ë	ì	í	î	ÿ	À	Á
9	É	é	è	ó	ö	ó	ü	ü	ÿ	ö	ü	ç	é	¥	Ä	Å	ä	å
A	á	à	í	ó	ú	ñ	ñ	¿	ó	ü	ç	é	¥	Ä	Å	ä	å	
B	.....	.....	.....	.....	.....	.....	.....	.....	.....	.....	.....	.....	.....	.....	.....	.....	.....	.....
C	.....	.....	.....	.....	.....	.....	.....	.....	.....	.....	.....	.....	.....	.....	.....	.....	.....	.....
D	.....	.....	.....	.....	.....	.....	.....	.....	.....	.....	.....	.....	.....	.....	.....	.....	.....	.....
E	.....	.....	.....	.....	.....	.....	.....	.....	.....	.....	.....	.....	.....	.....	.....	.....	.....	.....
F	.....	.....	.....	.....	.....	.....	.....	.....	.....	.....	.....	.....	.....	.....	.....	.....	.....	.....

## (5) Boldface PS

L\H	0	NUL	1	DLE	2	!	3	0	4	@	5	P	6	`	7	p	8	Ç	9	É	A	á	í	ó	ù	ñ	N	ë	ö	ó	ü	ÿ	Ö	Ü	Φ	£	¥	R	f
	1	SOH	2	DC1	3	"	4	1	5	A	6	Q	7	a	8	q	9	ü	0	æ	1	á	í	ó	ù	ñ	N	ë	ö	ó	ü	ÿ	Ö	Ü	Φ	£	¥	R	f
	2	STX	3	DC2	4	#	5	2	6	B	7	R	8	b	9	r	0	é	1	Æ	2	á	í	ó	ù	ñ	N	ë	ö	ó	ü	ÿ	Ö	Ü	Φ	£	¥	R	f
	3	♦	4	DC3	5	\$	6	3	7	C	8	S	9	c	0	s	1	á	2	Ø	3	á	í	ó	ù	ñ	N	ë	ö	ó	ü	ÿ	Ö	Ü	Φ	£	¥	R	f
	4	♦	5	DC4	6	%	7	4	8	D	9	T	0	ä	1	t	2	á	3	Ω	4	á	í	ó	ù	ñ	N	ë	ö	ó	ü	ÿ	Ö	Ü	Φ	£	¥	R	f
	5	♦	6	S	7	&	8	5	9	E	0	U	1	å	2	u	3	á	4	δ	5	á	í	ó	ù	ñ	N	ë	ö	ó	ü	ÿ	Ö	Ü	Φ	£	¥	R	f
	6	♦	7	SYN	8	'	9	6	0	F	1	V	2	e	3	v	4	á	5	∞	6	á	í	ó	ù	ñ	N	ë	ö	ó	ü	ÿ	Ö	Ü	Φ	£	¥	R	f
	7	BEL	8	ETB	9	(	0	7	0	G	1	W	2	f	3	w	4	á	5	∅	6	á	í	ó	ù	ñ	N	ë	ö	ó	ü	ÿ	Ö	Ü	Φ	£	¥	R	f
	8	BS	9	CAN	0	)	1	8	1	H	2	X	3	g	4	x	5	á	6	Ω	7	á	í	ó	ù	ñ	N	ë	ö	ó	ü	ÿ	Ö	Ü	Φ	£	¥	R	f
	9	HT	0	EM	1	*	2	9	2	I	3	Y	4	h	5	y	6	á	7	δ	8	á	í	ó	ù	ñ	N	ë	ö	ó	ü	ÿ	Ö	Ü	Φ	£	¥	R	f
	A	LF	1	SUB	2	+	3	0	3	J	4	Z	5	i	6	z	7	á	8	∞	9	á	í	ó	ù	ñ	N	ë	ö	ó	ü	ÿ	Ö	Ü	Φ	£	¥	R	f
	B	VT	2	ESC	3	,	4	1	4	K	5	[	6	j	7	{	8	á	9	∞	0	á	í	ó	ù	ñ	N	ë	ö	ó	ü	ÿ	Ö	Ü	Φ	£	¥	R	f
	C	FF	3	FS	4	-	5	2	5	L	6	\	7	k	8	}	9	á	0	∞	1	á	í	ó	ù	ñ	N	ë	ö	ó	ü	ÿ	Ö	Ü	Φ	£	¥	R	f
	D	CR	4	GS	5	=	6	3	6	M	7	]	8	l	9	~	0	á	1	∞	2	á	í	ó	ù	ñ	N	ë	ö	ó	ü	ÿ	Ö	Ü	Φ	£	¥	R	f
	E	SO	5	RS	6	>	7	4	7	N	8	^	9	m	0	~	1	á	2	∞	3	á	í	ó	ù	ñ	N	ë	ö	ó	ü	ÿ	Ö	Ü	Φ	£	¥	R	f
	F	SI	6	US	7	/	8	5	8	O	9	_	0	n	1	~	2	á	3	∞	4	á	í	ó	ù	ñ	N	ë	ö	ó	ü	ÿ	Ö	Ü	Φ	£	¥	R	f



## TYPES OF FONT CARDS

Cards from Fujitsu include Orator, Letter Gothic 12, Scientific 12, Boldface PS and Light Italic. Check with your Dealer/Distributor for additional information on font cards.

## INSTALLING A FONT CARD

Pull out the card from the vinyl case.

### NOTE:

It is better to insert or remove your font card during power on state because the printer gives you installation messages.

See Figure B-1. Insert your font card with the "FONT CARD" label facing upward until it is clicked in. Then the buzzer will shortly beep twice and the display will briefly show "CARD is inserted" for your confirmation.

### CAUTION:

Be sure to orient the font card correctly.

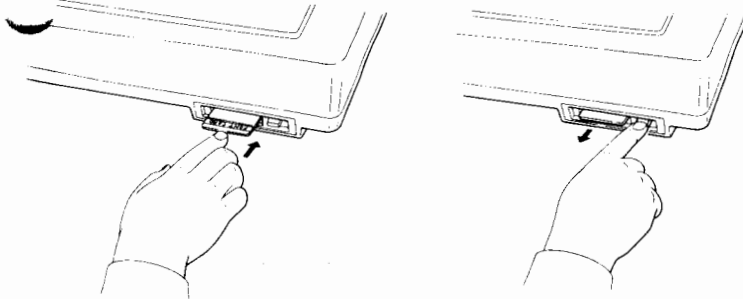

**Figure B-1** Inserting the font card

To remove the font card, press the eject button while the printer is in the idle state; the card will pop out of the slot. Then the buzzer will shortly beep twice and the display will briefly show "CARD is removed" for your confirmation.

### NOTE:

Take care not to drop or bend the font card.

## USING YOUR FONT CARD

Generally, one card contains two types of fonts. Select either font by changing "FONT" in setup mode or from your host computer.

To specify the font from the control panel:

1. Set the control panel in setup mode (see Section 3) and select the item "FONT".
2. Select the font name or font number (FNTCRD0 to FNTCRD7, generally 0 or 1) indicated on the carton label.
3. Change the item to "CHAR SP".
4. Select the character spacing (generally 10 CPI, 12 CPI, or PROP SP) also indicated on the carton label.

Example:

Select "FONT:ORATOR" and "CHAR SP:10 CPI" for the Orator.

Select "FONT:LT.ITAL" and "CHAR SP:12 CPI" for the Light Italic 12.

(For the font cards listed on "SUPPLIES, OPTIONS, AND PUBLICATIONS", the font name is displayed on the control panel.)

In online mode, send a font select command (see Section 5) from the host computer to your printer. For details, refer to your software manual or the Programmer's Manual of the printer.

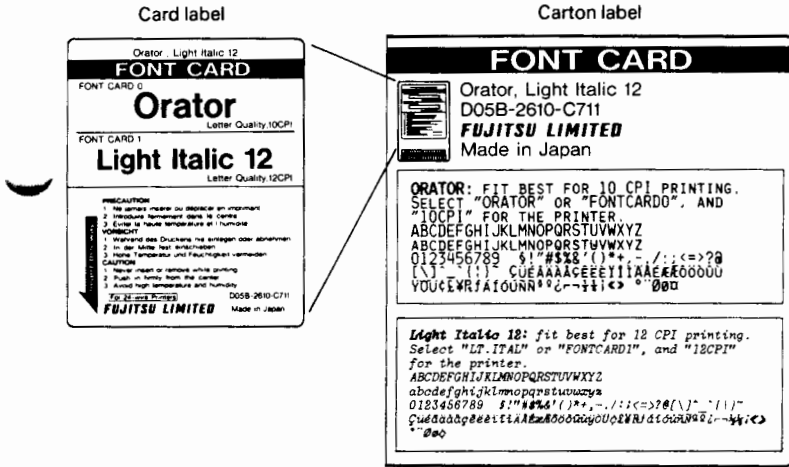

Figure B-2 Font card label



# APPENDIX C

## INTERFACE SPECIFICATIONS

The printer can communicate with a computer through both parallel (Centronics) and serial (RS-232C) interfaces. The parallel interface is standard, and the serial interface is optional and installed at the factory.

### C.1 PARALLEL INTERFACE

#### Hardware Requirements

Signal levels: TTL compatible

0.0 to +0.4 V for low level

+2.4 to +5.0 V for high level

Output circuit: SN74LS07 or equivalent

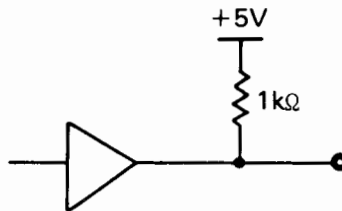

Figure C-1 Parallel interface output circuit

Input circuit: SN74LS14 or equivalent

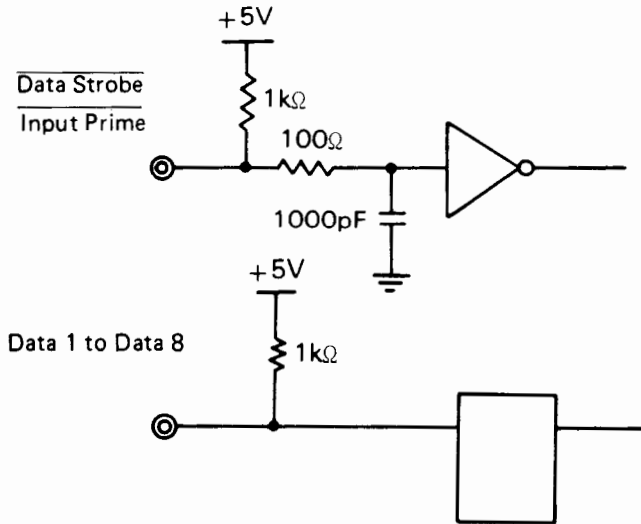

Figure C-2 Parallel interface input circuit

### Connector Pin Assignment

Connector (cable side): Shielded plug

Amphenol DDK 57FE-30360 or equivalent

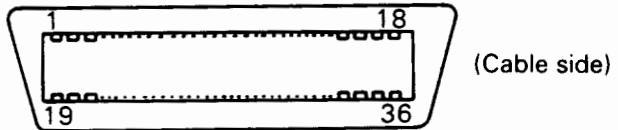

Figure C-3 Parallel interface connector

Signal definition:

**Table C-1 Parallel interface signals**

Connector pin number	Return line pin number	Signal name	Direction	Description
1	19	Data Strobe	In	<ul style="list-style-type: none"> <li>– Strobe pulse for reading data (Data 1 to Data 8). The printer reads the data when this signal is low.</li> <li>– Pulse width must be 1 <math>\mu</math>s or more at the printer receive terminal.</li> </ul>
2	20	Data 1	In	<ul style="list-style-type: none"> <li>– The Data 1 to Data 8 signals correspond to parallel data bits 1 to 8.</li> <li>– Data 8 is the most significant bit, but is not used in 7-bit ASCII mode.</li> <li>– All signals must go high at least 1 <math>\mu</math>s before the falling edge of the Data Strobe signal and must stay high for at least 1 <math>\mu</math>s after the rising edge.</li> </ul>
3	21	Data 2	In	
4	22	Data 3	In	
5	23	Data 4	In	
6	24	Data 5	In	
7	25	Data 6	In	
8	26	Data 7	In	
9	27	Data 8	In	
10	28	Acknowledge	Out	<ul style="list-style-type: none"> <li>– Pulse signal indicating data receive completed (or data receive enable) status.</li> <li>– It is also issued when the printer switches from the offline state to the online state.</li> </ul>

Table C-1 – continued

Connector pin number	Return line pin number	Signal name	Direction	Description
11	29	Busy	Out	Data cannot be received when this signal is high, for example, when the buffer is full or when an error occurs.
12	30	Peper Empty	Out	This signal goes high when paper runs out.
13	—	Select	Out	Indicates the selected (online) state when the signal is high and the deselected (offline) state when it is low.
14	—	—		Not used
15	—	—		Not used
16	—	Signal Ground (SG)		Logic ground level (0 V)
17	—	Frame Ground (FG)		Printer cabinet ground line. FG and SG are not connected.
18	—	—		Not used
19 to 30	—	Signal Ground (SG)		Twisted pair return lines
31	—	$\overline{\text{Input Prime}}$	In	If this signal is low for more than 50 $\mu\text{s}$ , the printer is reset to the initial status and placed online.
32	—	$\overline{\text{Fault}}$	Out	This signal goes low under the following printer conditions: (1) Offline (2) Paper out (3) Cover open (optional) (4) Cut sheet feeder error (5) Other printer error



**Table C-1 – continued**

Connector pin number	Return line pin number	Signal name	Direction	Description
33		—		Not used
34		—		Not used
35		—		Not used
36		—		Not used

**NOTES:**

1. Direction:  
 "In" indicates an input signal to the printer.  
 "Out" indicates an output signal from the printer.
2. Return line:  
 Represents a twisted pair return line which is connected to signal ground level.

## Data Transmission Timing

This printer receives data from the host in handshake mode based on the Busy and Acknowledge signals from the printer and the Data Strobe signal from the host.

For the Data Strobe and Acknowledge signals, the timing of the Busy signal must be as shown in the figure below.

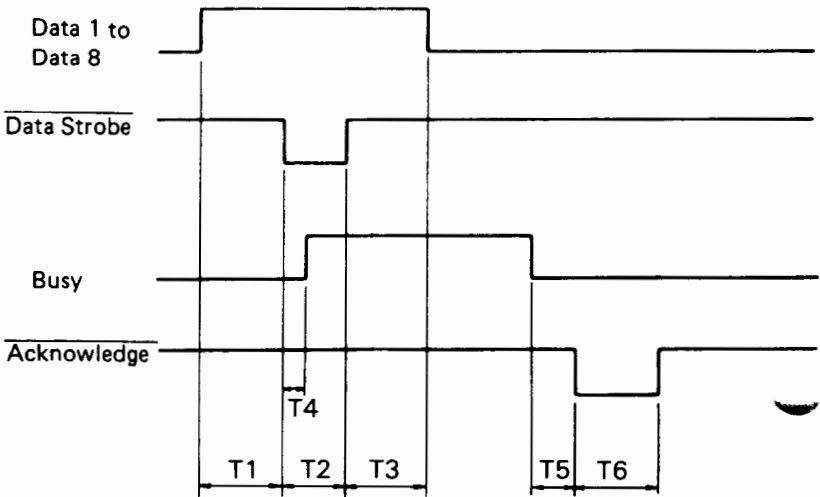

$$T1, T2, T3 > 1 \mu s$$

$$T4 < 1 \mu s$$

$$0 \mu s \leq T5 < 3 \mu s$$

$$2 \mu s < T6 < 6 \mu s$$

Figure C-4 Data transmission timing

## C.2 SERIAL INTERFACE

Transmission mode:

Asynchronous

Full duplex or half duplex (selectable)

Speeds:

600, 1200, 2400, 4800, 9600, or 19200 baud (selectable)

Data bits:

7 or 8 bits (selectable)

Parity bit:

Odd, even, mark, space, or none (selectable)

Start bit:

1 bit

Stop bit:

1 or 2 bits (selectable)

Protocol:

1. X-ON/X-OFF (DC1/DC3)
2. Data Terminal Ready (DTR)
3. Reverse Channel (RC)
4. ETX/ACK

Buffer size:

256, 2K, 8K, or 24K bytes (selectable)

## Hardware Requirements

Signal levels:

- 3 V or lower for a mark condition (logical 1)
- +3 V or higher for a space condition (logical 0)

Input circuit:

An MC1489AL is used to convert from the RS-232C level to the TTL level.

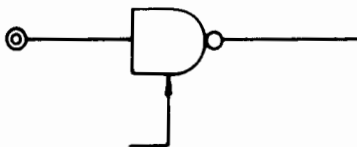

**Figure C-5** Serial interface input circuit

Output circuit:

An MC1488L is used to convert from the TTL level to the RS-232C level. A 1000-pF capacitor suppresses noise on the output signal line.

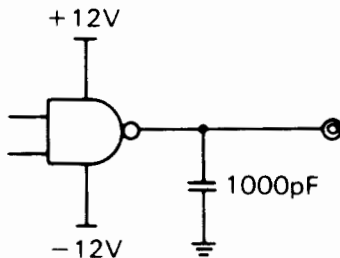

**Figure C-6** Serial interface output circuit

## Connector Pin Assignment

Connector (cable side):

D-subminiature Cannon or Cinch DB-25 male type or an equivalent connector that conforms to EIA standards

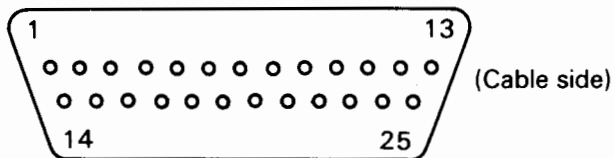

Figure C-7 Serial interface connector

Signal definition:

**Table C-2 Serial interface signals**

Pin number	Designation	Direction	Function
1	FG		Frame/Chassis Ground Safety/Protective ground
2	TD	Output	Transmitted Data
3	RD	Input	Received Data
4	RTS	Output	Request to Send Space state when the printer is ready to transmit data
5	CTS	Input	Clear to Send Space state when the host is ready to receive data
6	DSR	Input	Data Set Ready The printer can receive or transmit data when this signal is in the space state.
7	SG		Signal Ground (common return)
8	CD	Input	Carrier Detect The printer can receive data when this signal is in the space state.
11	(RC)	Output	(Reverse Channel) Available as a printer ready signal (Not used for the standard interface)
20	DTR	Output	Data Terminal Ready Space state when the printer is ready to receive or transmit data

**NOTES:**

1. The space state corresponds to the high level of the interface signal.
2. The direction (output or input) refers to the printer side.

## Serial Data Format

The format of serial data, 10 or 11 bits long, consists of a start bit, data bits, a parity bit, and stop bits. A bit is in the mark state when not in transmission. The data bits start with the least significant bit (LSB). For example, transmission of the character "K" (hexadecimal 4B) is shown below. (7 data bits, even parity)

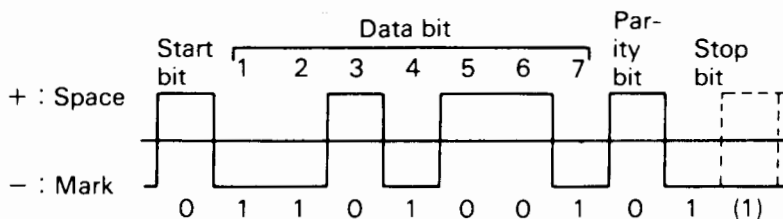

Figure C-8 Serial data format

## Timing Diagram and Cable Configuration

Your printer enables or disables the input control signals for the printer linked with the RS-232C interface. Thus, it enables communication via the RS-232C interface as well as more simple communication.

There are mainly two ways for cabling the RS-232C interface:

- Full-wire
- 3-wire

**(1) Full duplex all-wire control mode**

Timing chart:

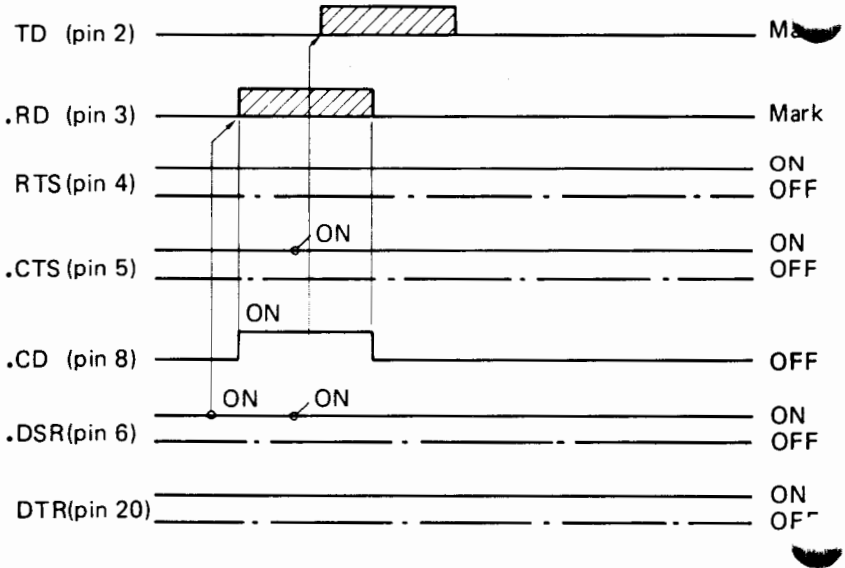
**Note:**

Signals prefixed by a dot ( . ) mark are input to the printer.

- ① DSR must be high (ON) when the printer receives data in this mode. Otherwise, received data is rejected.
- ② If both DSR and CTS are ON when the printer has data to be transmitted to the host in this mode, the printer transmits the data immediately. If either DSR or CTS is OFF, data is not transmitted until both signals go high (ON).
- ③ In this mode, CD is "don't care".



An example of cable configuration:

To DCE (data circuit terminating equipment)

Use the "straight-through" cable.

To DTE (data terminal equipment)

Be sure to use the "cross-patched" cable as shown below.

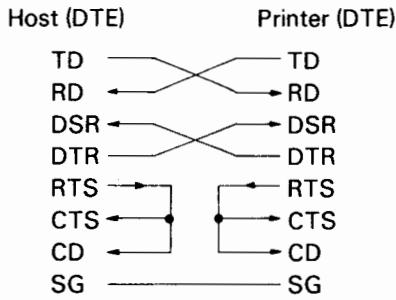

**(2) Full duplex 3-wire control mode**

This mode enables more simple communication than the above mode.

An example of cable configuration:

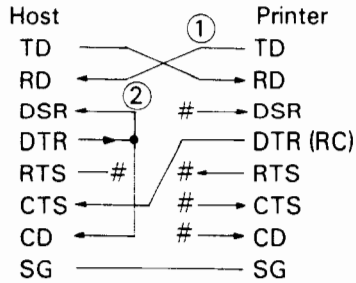

# : Indicates the open wire.

**Notes:**

1. Wire ① is unnecessary for the DTR (or RC) protocol.
2. Some hosts may not require wire ②.

## Data Protocols

Different types of protocols are available for the RS-232 C serial interface depending on the computer manufacturer. Check your computer manual for which of the following four protocols your computer uses:

- X-ON/X-OFF or DC1/DC3
- DTR
- RC
- ETX/ACK

These protocols are provided for preventing overflow of the print data receive buffer because the interface data transmission speed is faster than the buffer data print speed. Therefore, the printer uses specific character codes or an interface signal for each protocol to inform the host of the buffer status.

The ETX/ACK protocol is valid only when character set 1 of the IBM graphic printer is selected.

### (1) X-ON/X-OFF or DC1/DC3 protocol

With either protocol, the XOFF (DC3) code (hexadecimal 13) is transmitted from the printer when the remaining space in the buffer is less than 255 bytes. The XON (DC1) code (hexadecimal 11) is transmitted when the amount of data in the buffer is less than 255 bytes.

Normal processing of data cannot be guaranteed if data is transmitted to the printer when sufficient buffer space is not available after the XOFF code has been transmitted.

When the printer is first turned on, the DTR signal is set to the space state (ready) and an XON (DC1) code is transmitted from the printer. When the printer is placed offline, the XOFF code is transmitted even if the buffer is not full. The XON code is transmitted when the printer is placed online again.

If paper runs out or the optional cover is open a NAK code (hexadecimal 15) is sent from the printer.

## **(2) DTR protocol**

With this protocol, the DTR signal (pin 20) is set OFF (Low level). That is, the Busy signal is issued when the amount of data remaining in the buffer is 255 bytes. When the printer is placed offline, the DTR signal becomes inactive.

The transmitter must stop transmission within 255 bytes after the DTR signal is set OFF (Low level).

Valid data cannot be guaranteed if data exceeding the buffer capacity is transmitted without regard to the DTR signal.

Buffer-full recovery timing:

Data transmission is suspended when the DTR signal is set OFF (Low level). Even in this state, printing continues. When the data length of the available area in the buffer exceeds 255 bytes, the DTR signal is ON (High level). That is, a READY signal is issued.

## **(3) RC protocol**

This protocol is the same as the DTR protocol, except that it uses the Reverse Channel signal (pin 11) instead of the Data Terminal Ready signal (pin 20).

## **(4) ETX/ACK protocol**

With this protocol, the printer sends the ACK (Acknowledge) character (hexadecimal 06) to the computer when it reads out the ETX (End of Text) character (hexadecimal 03) from its print data receive buffer and does not print the ETX character.

The host computer transmits fixed-length messages whose length is a half of the buffer size or less. Every message ends with the ETX character.

When the first message is transmitted to the printer, the print operation begins while the computer sends the second message to the printer sequentially. Then the printer enters the receive buffer full state. The printer sends the ACK character when the ETX character (end of the first message) is detected. The computer stops sending the third message to the printer.

Receive buffer overflow can be prevented by this procedure. The computer does not send the next message until it receives the ACK character (except for the first two messages).

Data transmission continues unless the printer finishes printing two messages (enough to fill the receive buffer).

High-efficiency, high-throughput data communication is provided by this protocol.

Note that this protocol is available only when IBM character set 1 is selected.

—

—

—

(For use outside the United States)

## APPENDIX D

# EXCHANGING RIBBON SUBCASSETTES

The ribbon subcassette is a paper case housing only a ribbon. You can use a four-color ribbon subcassette in a four-color ribbon cassette or a black ribbon subcassette in a black ribbon cassette.

The black type can be replaced five times for one ribbon cassette and the four-color type can be four times. The ribbon cassette has an instruction label for recording the number of subcassette replacements. Circle a number each time you replace ribbon subcassette. When number 6 or 5 has been circled, you have to replace the ribbon cassette with a new one.

procedures for exchanging subcassettes are almost the same for four-color and black-color ribbons except that the black ribbon is twisted half a turn, like the Mobius strip, to form a dual track ribbon and lengthen the life of the ribbon.

### Four-color ribbon

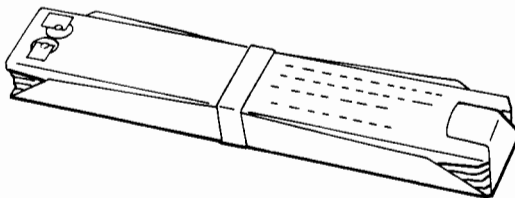
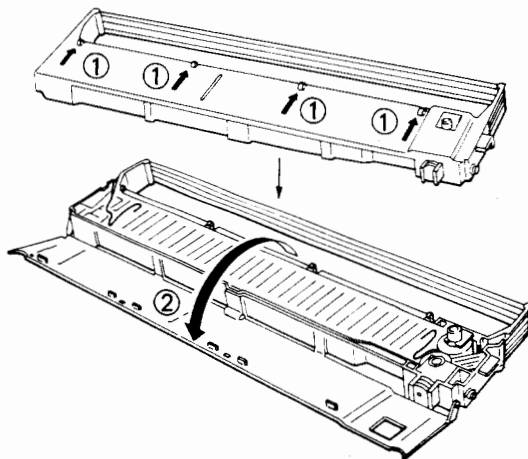

Figure D-1 Four-color ribbon subcassette

1. Unlock the four catches, one by one, in the direction of arrow.
2. Open the cassette cover.



**Figure D-2 Replacing the four-color ribbon subcassette (1 of 6)**

3. Pull the rubber roller in the direction of the arrow until it clicks, and lift and remove the used ribbon out of the cassette.

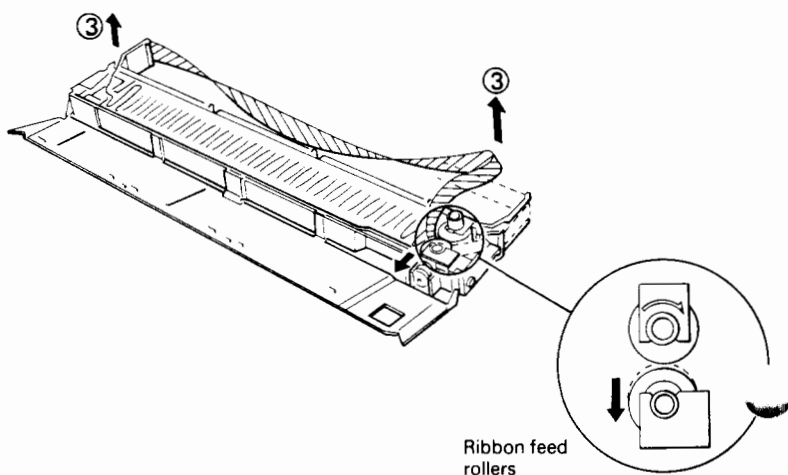

**Figure D-3 Replacing the four-color ribbon subcassette (2 of 6)**



4. Set a new subcassette in the ribbon cassette (be careful), and tear and remove the subcassette wrapping paper tape.
5. While gently holding the case in place, take out the tab inserted in the case by pulling it out.

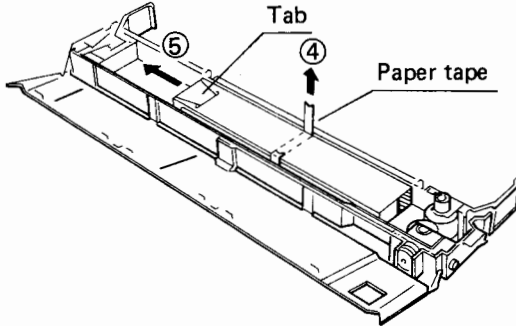

**Figure D-4 Replacing the four-color ribbon subcassette (3 of 6)**

6. Carefully arrange the ribbon along ribbon paths as shown in the figure.

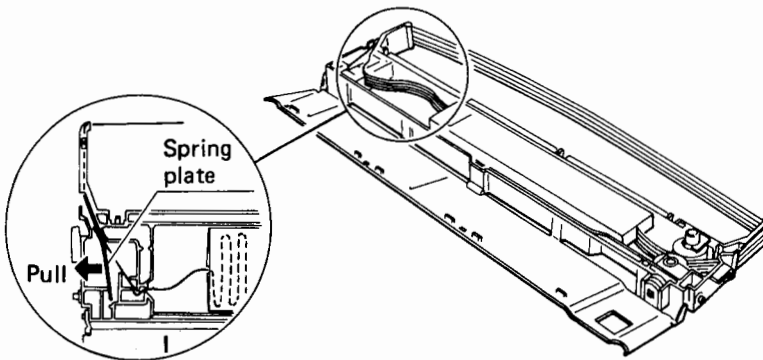

**Figure D-5 Replacing the four-color ribbon subcassette (4 of 6)**

7. Slowly lift the subcassette case out of the cassette.
8. Unlock the ribbon release knob in the direction of the arrow.
9. Turn the ribbon feed knob clockwise two or three times to check the ribbon feed operation.

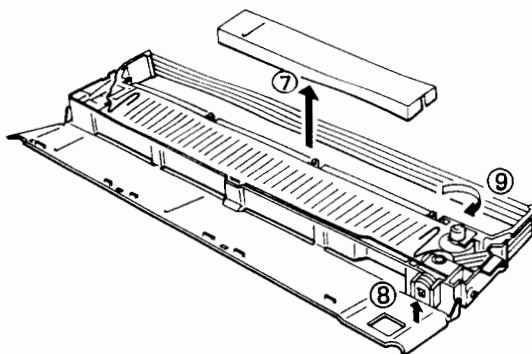

**Figure D-6 Replacing the four-color ribbon subcassette (5 of 6)**

10. Close the cassette cover and circle the number of subcassette replacements on the label.

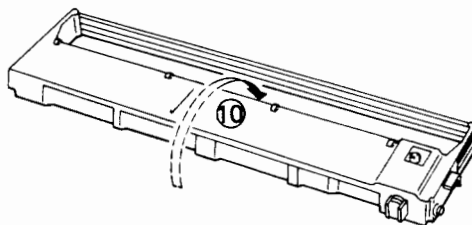

**Figure D-7 Replacing the four-color ribbon subcassette (6 of 6)**

## Black ribbon

1. Unlock the four catches, one by one, in the direction of arrow.
2. Open the cassette cover.

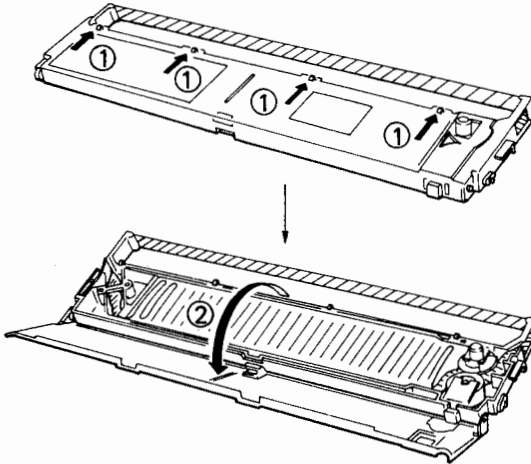

Figure D-8 Replacing the black ribbon subcassette (1 of 6)

3. Pull the rubber roller in the direction of the arrow until it clicks, and lift and remove the used ribbon with the ribbon guide out of the cassette.

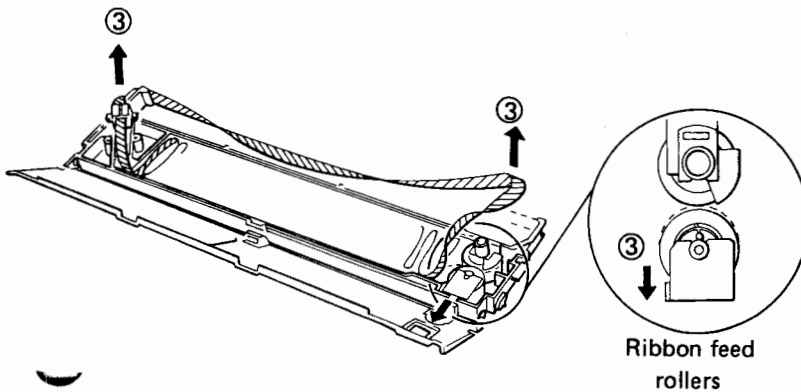
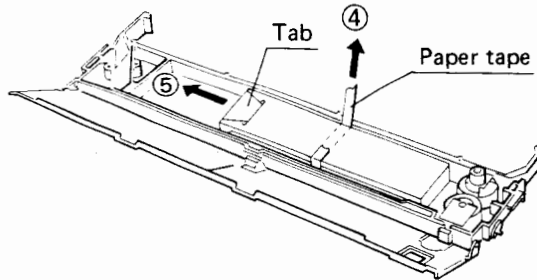

Figure D-9 Replacing the black ribbon subcassette (2 of 6)

4. Set a new subcassette in the ribbon cassette (be careful), and tear and remove the subcassette wrapping paper tape.
5. While gently holding the case in place, take out the tab inserted in the case by pulling it out.



**Figure D-10 Replacing the black ribbon subcassette (3 of 6)**

6. Pass the ribbon through the ribbon guide and put the guide into the slot so that the ribbon can be twisted half a turn counterclockwise viewed from the ribbon outlet (a quarter of a turn at the guide).
7. Carefully arrange the ribbon along ribbon paths as shown in the figure.

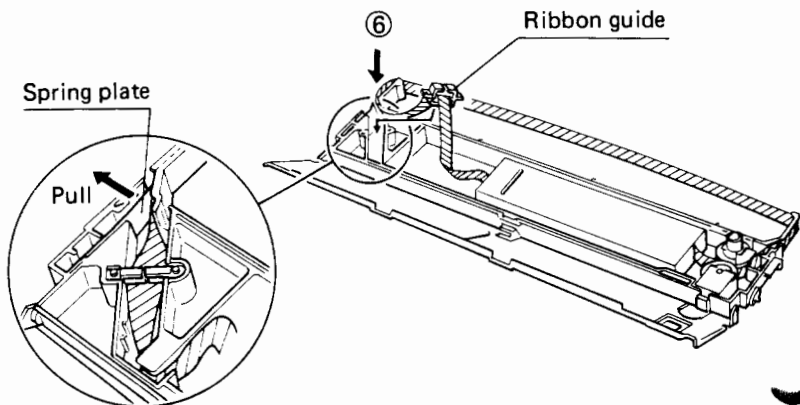

**Figure D-11 Replacing the black ribbon subcassette (4 of 6)**

8. Slowly lift the subcassette case out of the cassette.
9. Unlock the ribbon release knob in the direction of the arrow.
10. Turn the ribbon feed knob clockwise two or three times to check the ribbon feed operation.

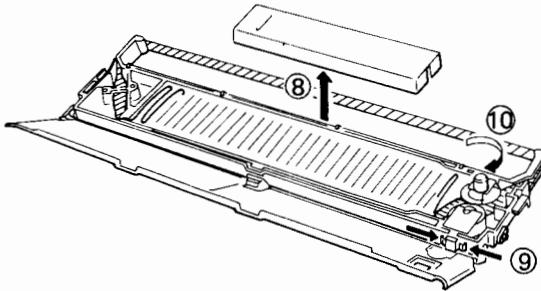

**Figure D-12 Replacing the black ribbon subcassette (5 of 6)**

11. Close the cassette cover and circle the number of subcassette replacements on the label.

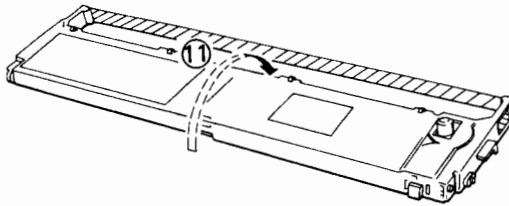

**Figure D-13 Replacing the black ribbon subcassette (6 of 6)**



# APPENDIX E

## PRINTER SPECIFICATIONS

### Command set:

Compatible with Fujitsu DPL24I (DotMax 24I). Includes most of the commands for the IBM Graphics printer, IBM Proprinter XL, Diablo 630 API printer and Epson FX-80 printer. It has additional word processing, graphics, and cut sheet feeder commands. Color commands are compatible with the Fujitsu DPL24C (DotMax 24C) and Epson JX-80 color printers.

### Dimensions:

Height: 7.3 inches (186 mm)  
Width: 23.6 inches (600 mm)  
Depth: 15.1 inches (385 mm)  
Weight: 45.2 pounds (20.5 kg)

### Operating environment:

41°F to 100°F (5°C to 38°C)  
20% to 85% RH (no condensation)

### Storage environment:

-4°F to 140°F (-20°C to 60°C)  
10% to 90% RH (no condensation)

### AC power:

100 to 120 VAC  $\pm$  10%, 50/60 Hz  
220 to 240 VAC  $\pm$  10%, 50/60 Hz

### Ribbon:

Four-color fabric or Black fabric ribbon in an easily installed cassette.

4-color ribbon for transparency film

Up to 3.6 million characters per color band with the color in draft ribbon, up to 15 million characters with the black ribbon, and up to 2.5 million characters with the color ribbon for transparency film.

**Character sets & Character fonts:**

IBM Graphics printer character set 1  
IBM Graphics printer character sets 2  
IBM Proprinter all character set

International character sets

Character fonts are Courier 10, Prestige Elite 12, Boldface PS, Compressed, or an optional font card.

**Optional font cards:**

Letter Gothic 12, Scientific 12, Orator and Light Italic 12.

Two fonts per card. Check with your dealer/distributor for the latest information on fonts.

**Character matrix: (Horizontal × vertical)**

Draft quality has 12 × 24 dots.

Letter quality has 36 × 24 dots.

**Print method:**

Impact dot matrix with a 24-wire print head.

**Printing speed:**

Draft Quality prints 486 characters per second at 12 CPI (405 at 10 CPI).

Correspondence quality prints 324 characters per second at 12 CPI (270 CPS at 10 CPI).

Letter Quality prints 162 characters per second at 12 CPI (135 CPS at 10 CPI).

Graphics prints 27 inches per second at 180 dpi.

**Character spacing:**

1/10", 1/12", 1/15", 1/17", 1/18", 1/20", or proportional spacing set with the control panel. Programmed with the host in increments of 1/120" or 1/180".

**Line spacing:**

1/3", 1/4", 1/6" or 1/8" set with the control panel. Programmed with the host for increments of 1/180" or 1/60" for image graphics.

**Number of copies:**

Up to 8, including the original.

(When you need seven or eight copies, be sure to test and estimate the paper.)



**Continuous form:**

4" to 16.5" wide, up to 0.016 inch (0.40 mm) thick.

**Paper handling:**

Friction feed platen and rear feed forms tractors are standard.

Optional cut sheet feeders, as described in Appendix A.

**Interface:**

Centronics type parallel.

Centronics type parallel plus RS-232C serial.

—

—

—

# APPENDIX F CHARACTER SET TABLES

## VI Graphics printer character set 1

L\H	0	1	2	3	4	5	6	7	8	9	A	B	C	D	E	F
	NUL	DLE	SP	0	@	P	~	p	NUL	DLE	á	☐	┌	└	α	≡
	SOH	DC1	!	1	A	Q	a	q	SOH	DC1	í	▒	┐	┘	β	±
	STX	DC2	"	2	B	R	b	r	STX	DC2	ó	▓	┌	┘	Γ	≥
	ETX	DC3	#	3	C	S	c	s	ETX	DC3	ú	▒	┐	┘	Π	≤
	EOT	DC4	\$	4	D	T	d	t	EOT	DC4	ñ	▒	┐	┘	Σ	┌
	ENQ	NAK	%	5	E	U	e	u	ENQ	NAK	Ñ	▒	┐	┘	o	┌
	ACK	SYN	&	6	F	V	f	v	ACK	SYN	á	▒	┐	┘	μ	┌
	BEL	ETB	'	7	G	W	g	w	BEL	ETB	ä	▒	┐	┘	τ	┌
	BS	CAN	(	8	H	X	h	x	BS	CAN	å	▒	┐	┘	φ	┌
	HT	EM	)	9	I	Y	i	y	HT	EM	æ	▒	┐	┘	θ	┌
	LF	SUB	*	:	J	Z	j	z	LF	SUB	ç	▒	┐	┘	Ω	┌
	VT	ESC	+	;	K	[	k	{	VT	ESC	ê	▒	┐	┘	δ	┌
	FF	FS	,	<	L	\	l		FF	FS	ë	▒	┐	┘	∞	┌
	CR	GS	-	=	M	]	m	}	CR	GS	ì	▒	┐	┘	∅	┌
	SO	RS	.	>	N	^	n	~	SO	RS	í	▒	┐	┘	€	┌
	SI	US	/	?	O	_	o	DEL	SI	US	«	▒	┐	┘	∩	┌
											»	▒	┐	┘		SP

Appendixes

# IBM Graphics printer character set 2

L\H	0	1	2	3	4	5	6	7	8	9	A	B	C	D	E	F
	NUL	SOH	STX	♦	♦	♦	♦	BEL	BS	HT	LF	VT	FF	CR	SO	SI
	DLE	DC1	DC2	DC3	DC4	§	SYN	ETB	CAN	EM	SUB	ESC	FS	GS	RS	US
2	SP	!	"	#	\$	%	&	'	(	)	*	+	,	-	.	/
3	0	1	2	3	4	5	6	7	8	9	:	;	<	=	>	?
4	@	A	B	C	D	E	F	G	H	I	J	K	L	\	]	^
5	P	Q	R	S	T	U	V	W	X	Y	Z	[	\	]	^	_
6	~	a	b	c	d	e	f	g	h	i	j	k	l	m	n	o
7	p	q	r	s	t	u	v	w	x	y	z	{		}	~	DEL
8	Ç	ü	é	â	ä	à	á	ç	ê	ë	è	ï	í	ì	Ä	Å
9	É	æ	Æ	ô	ö	ò	û	ù	ÿ	Ö	Ü	Ç	£	¥	R	f
A	á	í	ó	ú	ñ	Ñ	æ	ø	¿	¡	½	¼	¡	«	»	
B	·	·														
C	L	┘	T	┘	┘	┘	┘	┘	┘	┘	┘	┘	┘	┘	┘	┘
D	⊥	⊥	⊥	⊥	⊥	⊥	⊥	⊥	⊥	⊥	⊥	⊥	⊥	⊥	⊥	⊥
E	α	β	Γ	π	Σ	ο	μ	τ	φ	θ	Ω	δ	∞	∅	€	∩
F	≡	±	>	≤	∫	∫	∫	∫	∫	∫	∫	∫	∫	∫	∫	∫

# IBM Proprinter all character set

0	ø	☉	●	♥	◆	♣	♠	•	◻	○	◼	♂	♀	♫	♪	♬
1	▶	◀	↕	⋮	⋮	⋮	⋮	⋮	⋮	⋮	⋮	⋮	⋮	⋮	⋮	⋮
2	SP	!	"	#	\$	%	&	'	(	)	*	+	,	-	.	/
3	0	1	2	3	4	5	6	7	8	9	:	;	<	=	>	?
4	@	A	B	C	D	E	F	G	H	I	J	K	L	M	N	O
5	P	Q	R	S	T	U	V	W	X	Y	Z	[	\	]	^	_
6	`	a	b	c	d	e	f	g	h	i	j	k	l	m	n	o
7	p	q	r	s	t	u	v	w	x	y	z	{		}	~	□
8	Ç	ü	é	â	ä	å	á	ç	ê	ë	è	ï	í	ì	ï	À
9	É	æ	Æ	ô	ö	ò	û	ù	ÿ	ö	ü	ç	£	¥	℞	ƒ
A	á	í	ó	ú	ñ	Ñ	á	ó	¿	¡	¿	¿	¿	¿	¿	¿
B	☐	☐	☐	☐												
C	L	T	T	T	T	T	T	T	T	T	T	T	T	T	T	T
D	⊥	⊥	⊥	⊥	⊥	⊥	⊥	⊥	⊥	⊥	⊥	⊥	⊥	⊥	⊥	⊥
E	α	β	γ	π	Σ	o	u	ι	φ	θ	Ω	δ	∞	∅	ε	∩
F	≡	±	≈	≤	∫	∫	+	≈	•	•	•	√	∞	²	■	SP

## International character sets

Hex	23H	24H	40H	5BH	5CH	5DH	5EH	60H	7BH	7CH	7DH	7EH
Dec	35	36	64	91	92	93	94	96	123	124	125	126
USA	#	\$	@	[	\	]	^	~	{		}	~
FRENCH	£	§	à	•	ç	§	^	~	é	ù	è	..
GERMAN	#	§	§	Ä	Ö	Ü	^	~	ä	ö	ü	ß
UK	£	§	@	[	\	]	^	~	{		}	~
DANISH/ NORWEGN	#	§	£	Æ	Ø	Å	Ü	é	æ	ø	å	ü
SWEDISH/ FINNISH	#	¤	£	Ä	Ö	Å	Ü	é	ä	ö	å	ü
ITALIAN	£	§	§	•	ç	é	^	ù	à	ò	è	ì
SPANISH	£	§	§	ì	Ñ	¿	^	~	•	ñ	ç	~

# APPENDIX G

## CODE CONVERSION TABLES

The three character sets in the conversion table are as follows:

Set 1: IBM Graphics printer character set 1.

Specifiable by the ESC 7 command in the DPL24C or IBM-PRO emulation, or from the control panel.

Set 2: IBM Graphics printer character set 2.

Specifiable by the ESC 6 command in the DPL24C or IBM-PRO emulation, or from the control panel.

(\*): IBM Proprinter all printable character set.

Specifiable by the ESC \ or ESC ^ command in the IBM-PRO emulation.

Set1	Set2	*	Dec	Hex	Binary	Set1	Set2	*	Dec	Hex	Binary
NUL	NUL	∅	0	00	00000000	SP	SP	SP	32	20	00100000
SOH	SOH	⊕	1	01	00000001	!	!	!	33	21	00100001
STX	STX	⊙	2	02	00000010	"	"	"	34	22	00100010
ETX	♥	♥	3	03	00000011	#	#	#	35	23	00100011
EOT	♦	♦	4	04	00000100	\$	\$	\$	36	24	00100100
ENQ	‡	‡	5	05	00000101	%	%	%	37	25	00100101
ACK	◆	◆	6	06	00000110	&	&	&	38	26	00100110
BEL	BEL	•	7	07	00000111	'	'	'	39	27	00100111
BS	BS	■	8	08	00001000	(	(	(	40	28	00101000
HT	HT	○	9	09	00001001	)	)	)	41	29	00101001
LF	LF	☉	10	0A	00001010	*	*	*	42	2A	00101010
VT	VT	♂	11	0B	00001011	+	+	+	43	2B	00101011
FF	FF	♀	12	0C	00001100	,	,	,	44	2C	00101100
CR	CR	♪	13	0D	00001101	-	-	-	45	2D	00101101
SO	SO	♫	14	0E	00001110	.	.	.	46	2E	00101110
SI	SI	⚙	15	0F	00001111	/	/	/	47	2F	00101111
DLE	DLE	▶	16	10	00010000	0	0	0	48	30	00110000
DC1	DC1	◀	17	11	00010001	1	1	1	49	31	00110001
DC2	DC2	↕	18	12	00010010	2	2	2	50	32	00110010
DC3	DC3	!!	19	13	00010011	3	3	3	51	33	00110011
DC4	DC4	¶	20	14	00010100	4	4	4	52	34	00110100
NAK	§	§	21	15	00010101	5	5	5	53	35	00110101
SYN	SYN	-	22	16	00010110	6	6	6	54	36	00110110
ETB	ETB	↕	23	17	00010111	7	7	7	55	37	00110111
CAN	CAN	↑	24	18	00011000	8	8	8	56	38	00111000
EM	EM	↓	25	19	00011001	9	9	9	57	39	00111001
SUB	SUB	→	26	1A	00011010	:	:	:	58	3A	00111010
ESC	ESC	←	27	1B	00011011	;	;	;	59	3B	00111011
FS	FS	└	28	1C	00011100	<	<	<	60	3C	00111100
GS	GS	↔	29	1D	00011101	=	=	=	61	3D	00111101
RS	RS	▲	30	1E	00011110	>	>	>	62	3E	00111110
US	US	▼	31	1F	00011111	?	?	?	63	3F	00111111











Set1	Set2	(*)	Dec	Hex	Binary	Set1	Set2	(*)	Dec	Hex	Binary
@	@	@	64	40	01000000	~	~	~	96	60	01100000
A	A	A	65	41	01000001	a	a	a	97	61	01100001
B	B	B	66	42	01000010	b	b	b	98	62	01100010
C	C	C	67	43	01000011	c	c	c	99	63	01100011
D	D	D	68	44	01000100	d	d	d	100	64	01100100
E	E	E	69	45	01000101	e	e	e	101	65	01100101
F	F	F	70	46	01000110	f	f	f	102	66	01100110
G	G	G	71	47	01000111	g	g	g	103	67	01100111
H	H	H	72	48	01001000	h	h	h	104	68	01101000
I	I	I	73	49	01001001	i	i	i	105	69	01101001
J	J	J	74	4A	01001010	j	j	j	106	6A	01101010
K	K	K	75	4B	01001011	k	k	k	107	6B	01101011
L	L	L	76	4C	01001100	l	l	l	108	6C	01101100
M	M	M	77	4D	01001101	m	m	m	109	6D	01101101
N	N	N	78	4E	01001110	n	n	n	110	6E	01101110
O	O	O	79	4F	01001111	o	o	o	111	6F	01101111
P	P	P	80	50	01010000	p	p	p	112	70	01110000
Q	Q	Q	81	51	01010001	q	q	q	113	71	01110001
R	R	R	82	52	01010010	r	r	r	114	72	01110010
S	S	S	83	53	01010011	s	s	s	115	73	01110011
T	T	T	84	54	01010100	t	t	t	116	74	01110100
U	U	U	85	55	01010101	u	u	u	117	75	01110101
V	V	V	86	56	01010110	v	v	v	118	76	01110110
W	W	W	87	57	01010111	w	w	w	119	77	01110111
X	X	X	88	58	01011000	x	x	x	120	78	01111000
Y	Y	Y	89	59	01011001	y	y	y	121	79	01111001
Z	Z	Z	90	5A	01011010	z	z	z	122	7A	01111010
[	[	[	91	5B	01011011	{	{	{	123	7B	01111011
\	\	\	92	5C	01011100	:	:	:	124	7C	01111100
]	]	]	93	5D	01011101	}	}	}	125	7D	01111101
^	^	^	94	5E	01011110	~	~	~	126	7E	01111110
_	_	_	95	5F	01011111	DEL	DEL	☐	127	7F	01111111

Set1	Set2	*	Dec	Hex	Binary	Set1	Set2	*	Dec	Hex	Binary
NUL	ç	ç	128	80	10000000	á	á	á	160	A0	10100000
SOH	ù	ù	129	81	10000001	í	í	í	161	A1	10100001
STX	é	é	130	82	10000010	ó	ó	ó	162	A2	10100010
ETX	ã	ã	131	83	10000011	ú	ú	ú	163	A3	10100011
EOT	ä	ä	132	84	10000100	ñ	ñ	ñ	164	A4	10100100
ENQ	à	à	133	85	10000101	ñ	ñ	ñ	165	A5	10100101
ACK	á	á	134	86	10000110	â	â	â	166	A6	10100110
BEL	ç	ç	135	87	10000111	ë	ë	ë	167	A7	10100111
BS	ê	ê	136	88	10001000	¿	¿	¿	168	A8	10101000
HT	e	e	137	89	10001001	ƒ	ƒ	ƒ	169	A9	10101001
LF	è	è	138	8A	10001010	ƒ	ƒ	ƒ	170	AA	10101010
VT	i	i	139	8B	10001011	‡	‡	‡	171	AB	10101011
FF	î	î	140	8C	10001100	‡	‡	‡	172	AC	10101100
CR	l	l	141	8D	10001101	ı	ı	ı	173	AD	10101101
SO	â	â	142	8E	10001110	«	«	«	174	AE	10101110
SI	Á	Á	143	8F	10001111	»	»	»	175	AF	10101111
DLE	é	é	144	90	10010000				176	B0	10110000
DC1	æ	æ	145	91	10010001				177	B1	10110001
DC2	œ	œ	146	92	10010010	ˆ	ˆ	ˆ	178	B2	10110010
DC3	ø	ø	147	93	10010011				179	B3	10110011
DC4	o	o	148	94	10010100	†	†	†	180	B4	10110100
NAK	ò	ò	149	95	10010101	†	†	†	181	B5	10110101
SYN	ù	ù	150	96	10010110	‡	‡	‡	182	B6	10110110
ETB	û	û	151	97	10010111	‡	‡	‡	183	B7	10110111
CAN	ÿ	ÿ	152	98	10011000	ƒ	ƒ	ƒ	184	B8	10111000
EM	o	o	153	99	10011001	‡	‡	‡	185	B9	10111001
SUB	Û	Û	154	9A	10011010				186	BA	10111010
ESC	ç	ç	155	9B	10011011	ƒ	ƒ	ƒ	187	BB	10111011
FS	£	£	156	9C	10011100	„	„	„	188	BC	10111100
GS	¥	¥	157	9D	10011101	„	„	„	189	BD	10111101
RS	R	R	158	9E	10011110	„	„	„	190	BE	10111110
US	f	f	159	9F	10011111	ƒ	ƒ	ƒ	191	BF	10111111

Set1	Set2	(*)	Dec	Hex	Binary	Set1	Set2	(*)	Dec	Hex	Binary
ℓ	ℓ	ℓ	192	C0	11000000	α	α	α	224	E0	11100000
⊥	⊥	⊥	193	C1	11000001	β	β	β	225	E1	11100001
⊤	⊤	⊤	194	C2	11000010	Γ	Γ	Γ	226	E2	11100010
⊥	⊥	⊥	195	C3	11000011	π	π	π	227	E3	11100011
-	-	-	196	C4	11000100	Σ	Σ	Σ	228	E4	11100100
†	†	†	197	C5	11000101	ο	ο	ο	229	E5	11100101
⊥	⊥	⊥	198	C6	11000110	υ	υ	υ	230	E6	11100110
⊥	⊥	⊥	199	C7	11000111	τ	τ	τ	231	E7	11100111
⊥	⊥	⊥	200	C8	11001000	ϕ	ϕ	ϕ	232	E8	11101000
⊥	⊥	⊥	201	C9	11001001	θ	θ	θ	233	E9	11101001
⊥	⊥	⊥	202	CA	11001010	Ω	Ω	Ω	234	EA	11101010
⊥	⊥	⊥	203	CB	11001011	δ	δ	δ	235	EB	11101011
⊥	⊥	⊥	204	CC	11001100	∞	∞	∞	236	EC	11101100
=	=	=	205	CD	11001101	ø	ø	ø	237	ED	11101101
⊥	⊥	⊥	206	CE	11001110	€	€	€	238	EE	11101110
⊥	⊥	⊥	207	CF	11001111	∅	∅	∅	239	EF	11101111
⊥	⊥	⊥	208	D0	11010000	≡	≡	≡	240	F0	11110000
⊥	⊥	⊥	209	D1	11010001	±	±	±	241	F1	11110001
⊥	⊥	⊥	210	D2	11010010	≥	≥	≥	242	F2	11110010
⊥	⊥	⊥	211	D3	11010011	≤	≤	≤	243	F3	11110011
⊥	⊥	⊥	212	D4	11010100	∫	∫	∫	244	F4	11110100
⊥	⊥	⊥	213	D5	11010101	∫	∫	∫	245	F5	11110101
⊥	⊥	⊥	214	D6	11010110	‡	‡	‡	246	F6	11110110
⊥	⊥	⊥	215	D7	11010111	≈	≈	≈	247	F7	11110111
⊥	⊥	⊥	216	D8	11011000	•	•	•	248	F8	11111000
⊥	⊥	⊥	217	D9	11011001	•	•	•	249	F9	11111001
⊥	⊥	⊥	218	DA	11011010	•	•	•	250	FA	11111010
■	■	■	219	DB	11011011	✓	✓	✓	251	FB	11111011
■	■	■	220	DC	11011100	°	°	°	252	FC	11111100
■	■	■	221	DD	11011101	°	°	°	253	FD	11111101
■	■	■	222	DE	11011110	■	■	■	254	FE	11111110
■	■	■	223	DF	11011111	SP	SP	SP	255	FF	11111111

## GRAPHIC CHARACTERS (character = > decimal)

Graphics characters are designed to easily make graphs, tables, block diagrams, etc.

Character	Decimal	Character	Decimal
	176		220
	177		221
	178		222
	219		223

The following show examples of tables or blocks and decimal codes corresponding to rules on each table or block. (Relationship is indicated by arrows.)

**Table 1**

218	196	194	210	196	191
↓	↓	↓	↓	↓	↓
	—			—	
-179			-186		-179
-195	—	-197	-215	—	-180
-179			-186		-179
-198	≡	-216	-206	≡	-181
	205			205	
-192	—	-193	-208	—	-217

Table 2

201	205	203	=	209	=	187
┆	┆	┆	=	┆	=	┆
┆┆186		┆┆186		┆┆179		┆
┆┆199	—	┆┆215	—	┆┆197		┆┆182
┆┆186		┆┆186		┆┆179		┆
┆┆204	==	┆┆206	=	┆┆216	=	┆┆185
┆┆200	==	┆┆202	=	┆┆207	=	┆┆188

## Blocks

┆┆213	=	┆┆184		┆┆214	—	┆┆183
┆		┆┆179		┆		┆┆186
┆┆212	=	┆┆190		┆┆211	—	┆┆189



# GLOSSARY OF TERMS

## Line Fuse:

Protects the printer's power supply in case of a power overload or short circuit.

## AC Power Cord:

Provides electricity to the printer (two prongs for power and one plug for ground).

## Application Software:

Program that provides a solution to a particular problem such as maintaining an inventory or creating a report.

## ASCII:

An acronym for American Standard Code for Information Interchange, or the code sent to the printer with a unique binary coded number for each character.

## Bail Roller Unit:

A unit consisted of a movable bar with a cylindrical roller, used to hold the paper against the platen.

## Baud Rate:

The speed of data transmission to the printer. Applies to serial data only. Baud rate is equal to the number of bits transmitted per second.

## Bidirectional Printing:

The ability to print from left to right and then right to left to avoid carriage returns and increase printed output.

A bit is the smallest unit of data and has a value of 0 or 1.

**Bold Print:**

Printing twice with 2nd striking at the same position to darken characters without increasing the line thickness.

**Buffer:**

Storage area for incoming data.

**Byte:**

Eight bits that are considered as one symbol. Used to represent a single character such as a number, a letter, or a special control character.

**Card Guide:**

A plate to lead the paper under the bail roller when loading paper and prevent the paper from pressing the ribbon mask excessively. It has indicators to show the bottom line of characters.

**Carriage Return:**

The return of the print head to the beginning of the next line.

**Character:**

Any letter, number, or symbol.

**Command:**

An instruction that tells the computer what to do. A command usually consists of words, parts of words, or codes. The computer will only respond to those commands that are accepted by the program which the computer is currently running.

**Command Set:**

The series of print or format instructions imbedded in the printer firmware, and actuated by codes sent from the host computer.

**Compatibility:**

The ability of substituting for another printer, including both plug-compatible and command compatible.



**Condensed Print:**

Making the character width narrow to increase characters printed per line.

**Continuous Form:**

Another word for continuous fanfolded sheets of paper at perforation, with punched holes for tractor feeding.

**Cut Sheet Feeder:**

An optional unit capable of handling cut sheets or envelopes continuously.

**Data:**

Another word for information.

**Data circuit terminating equipment (DCE)**

The side of an interface that provides functions necessary for connection or signal transformation between data terminal equipment and data transmission line, usually modems.

**Data terminal equipment (DTE)**

The side of an interface that acts as a data source and/or sink, usually computers or computer terminals.

**Default:**

A printer parameter that the printer returns to power on state.

**Downloading:**

Transferring character font matrix data from the host system to the printer's memory to enable the user to print specially designed characters.

**Emulation:**

Exactly executing a command set defined for a different printer and producing the identical results.

**Font:**

A complete set of type in one size and style of characters.

**Font Card:**

An IC card storing matrix data of characters to enable the user to print various styles of fonts.

**Form Feed:**

A signal to the printer to advance the printer platen until the next top-of-form position is reached.

**Form Length:**

A printer setting for the spacing between top-of-form positions measured in inches.

**Format:**

The shape and appearance of printer output, including page size, character width and spacing, line spacing, etc.

**Friction Feed:**

Feeding of paper through the printer is accomplished by the friction between the platen and inserter rollers.

**Graphics Printing:**

Controlling the print head wires (dots) individually to produce any picture or image on a line, part of a page, or even an entire page.

**Interface:**

The connection that transfers electrical signals from one part of a system to another.

**Line Spacing:**

The vertical spacing between lines, measured in lines per inch.

**Matrix:**

An array of elements; in the case of printers the arrangement of the pins that form the letters through closely spaced dots.

**Platen:**

The rubber roller in the printer, which provides a backing for the printing action.

**Power Switch:**

The system's ON/OFF switch located on the right of the printer unit. This switch is labeled with the international designations 1 for ON and 0 for OFF.

**Process Color Ribbon:**

Inked ribbon with four color lanes (three primary colors and black) to produce colors by printing the lanes in the predetermined sequences.

**Proportional Spacing:**

Character width differs from one character to another. These characters require variable printhead spacing (proportional).

**Reset:**

A function performed by turning printer OFF and then ON again.

**Shadow Print:**

Printing twice with the 2nd striking slightly shifted to the right to emphasize characters.

**Top-of-Form:**

The very top of a page of text.

**Tractor Feed:**

A paper handling device for continuous forms. The tractor sprockets engage holes in the edge strip of the form, guiding and registering the paper.





# INDEX

control characters and ESC sequences, see Section 5 "Command Sets".	
AC power cord	
Connection .....	1-8
Received items .....	1-2
AC power specification .....	E-1
Adjusting print positions .....	2-8, 2-10
ALARM indicator .....	3-1
Arrangement of fold paper .....	2-7
Attribute of character (ATTRIB: setup item) .....	3-15
Auto CR See right end carriage return .....	3-17
Auto paper loading	
Continuous forms .....	2-5
Cut sheets .....	2-8
" lever .....	1-6
" rate (BAUD RT: setup item, serial) .....	3-21
Bidirectional printing (PRT DIR: setup option) .....	3-19
Boldface character	
Font .....	B-6
Selection (BOLDFCE: setup option) .....	3-14
Buffer allocation (BUFFER: setup item) .....	3-19
Buttons (FF, LF, ONLINE, RESET) .....	3-2
Buzzer cut-off (BUZZER: setup item) .....	3-19
Centronics parallel interface	
Connection .....	1-10
Selection (PARALEL: setup option) .....	3-20
Specifications .....	C-1
Character attribute (ATTRIB: setup item) .....	3-15
Character sets	
Table .....	F-1
Selection (CHR SET: setup item) .....	3-16
Character spacing (CHAR SP: setup item) .....	3-14
Cleaning .....	4-5
Code conversion table .....	G-1
Color print unit .....	2-1



Color selection	
Command .....	5-10, 5-22, 5-34
Control panel (COLOR: setup item) .....	3-15
Command compatibility .....	STANDARD FEATURES
Command set	
Emulations .....	5-1
DPL24C .....	5-2
DPL24D .....	5-17
IBM PRO .....	5-28
Communication protocol (PROTOCL: setup item) .....	3-21
Compression character	
Font .....	B-5
Selection (COMPRSD: setup option) .....	3-14
Continuous forms loading .....	2-5
Control panel	
Buttons .....	3-2
Holding down a button .....	3-6
Indicators .....	3-1
Message display (16-digit LCD) .....	1-6, 3-1
Control panel modes	
Alternate (SETUP/LOAD/MICROLF/ALT) .....	3-2, 3-5
Normal (ONLINE/FF/LF/RESET) .....	3-2, 3-5
Setup (EXIT/FUNCTION/ITEM/SELECTION) .....	3-2, 3-6
Copy	
Gluing of sheets .....	2-17
Number of copies .....	2-15, E-2
Paper thickness lever setting .....	2-13
Courier 10	
Font .....	B-2
Selection (COUR 10: setup option) .....	3-14
CR code definition (CR-CODE: setup item) .....	3-17
Cut sheet feeder	
Form length setting .....	A-4
Installation .....	A-1
Models .....	A-1
Paper handling .....	A-4
Ribbon exchanging .....	A-5
Type (FEEDER: setup item, ASF300) .....	A-5
Cut sheet loading	
Cut sheet feeder .....	A-4
Cut sheet paper guide .....	2-8

Cut sheet paper guide	
Installation	1-4
Printer elements	1-6
Received items	1-2
Data format (FORMAT: setup item, serial)	3-20
Data Terminal Ready (DTR) protocol	C-16
Data transmission duplex mode	3-21
DC1/DC3	
Code definition (DC3-CDE: setup item)	3-17
Protocol	C-15
Default (DEFAULT: setup function)	3-11, 3-24
Diablo 630 API emulation	
Command set	5-17
Selection (DIABLO: setup option)	3-15
Dimensions	E-1
Downloading commands	5-11, 5-23, 5-34
DPL24 type C/I emulation	
Command set	5-2
Selection (DPL24C or I: setup option)	3-15
DPL24 type D emulation	
Command set	5-17
Selection (DPL24D: setup option)	3-15
Draft quality	
Font	B-4
Selection (DRAFT: setup option)	3-14
Duplex mode (DUPLEX: setup item)	3-21
Eject button	B-7
Emulation	
Description	APPLICATION SOFTWARE SETUP, 5-1
Selection (EMULATE: setup item)	3-15
Environment conditions	E-1
Error messages	3-29
Error symptom and check	4-6
ETX/ACK protocol	C-16
Exchanging ribbon cassette	
Printer with cut sheet feeder	A-5
Printer without cut sheet feeder	2-5
Exchanging ribbon subcassette	D-1

Factory options .....	PREFACE
Factory setting of printer's features .....	Q-5, 3-9
FF button .....	3-3
Firmware revision .....	3-24
First print line (top of form)	
Adjustment .....	
Margin selection (TOP MRG: setup item) .....	3-16
Font card	
Font number (FNTCRDn: setup option) .....	3-14
Installation .....	1-6, B-7
Font selection (FONT: setup item) .....	3-14
Font table .....	B-1
Form length    See page length .....	3-15
Form length setting (cut sheet feeder) .....	A-4
Forms tractor .....	2-5
Front cover .....	1-6
Fuse replacement .....	4-3
FX-80/JX-80 printer emulation	
Command set .....	5-2
Selection (FX-80 or JX-80: setup option) .....	3-15
Graphic characters .....	
Graphic line feed (GRPH LF: setup item) .....	3-16
Graphics commands .....	5-13, 5-25, 5-35
Hardware & interface condition setting	
Items .....	3-18
Selection (HARDWARE: setup function) .....	3-11
Hex dump (HEX DUMP: setup function) .....	3-11, 3-26
IBM Graphics Printer emulation	
Command set .....	5-2
Selection (IBM GPH: setup option) .....	3-15
IBM Proprinter XL emulation	
Command set .....	5-28
Selection (IBM PRO: setup option) .....	3-15
Indicators (ALARM, ONLINE, POWER, SETUP) .....	3-1
Initialization .....	4-1
Input buffer allocation (BUFFER: setup item) .....	? ?
Installation precautions .....	
Installing ribbon cassette .....	2-1



Interface cable	
Configuration	C-11
Connecting procedure	Q-4, 1-10
Length and shield	FCC Statement
Parallel connector (Centronics type)	1-7, 1-10
Serial connector (RS-232C)	1-7, 1-10
Interface connector pin assignment	
Parallel	C-2
Serial	C-9
Interface signal definitions	
Parallel	C-3
Serial	C-10
Interface signal timings	
Parallel	C-6
Serial	C-11
Interface specifications	C-1
Interface type (INTRFCE: setup item)	3-20
International character sets	F-3
Language selection	
Commands	5-9, 5-21
Control panel (LANGUGE: setup item)	3-16
International character sets	F-3
Left end position offset (LFT END: setup item)	3-15
Letter quality	
Fonts (courier, prestige elite, boldface)	B-2, B-3, B-6
Selection (LETTER: setup option)	3-14
Levers	
Bail	1-6, 3-30
Paper path	1-6, 3-30
Paper thickness	1-6, 2-13
LF button	3-3
LF code definition (LF-CODE: setup item)	3-17
Line spacing (LINE SP: setup item)	3-14
Loading paper	
Continuous forms	2-5
Cut sheet	2-8
Orientation of glued multipart cut sheets	2-18
ation	4-5
Maintenance	4-5
Menu (MENU: setup function)	3-11, 3-13

Micro line feed .....	3-5
Multicopy .....	2-15, E-2
Multi-part paper gluing .....	2-17
Offline .....	2 3
ONLINE button .....	
ONLINE indicator .....	3-2
Options	
Cut sheet feeder .....	A-1
Font card .....	B-1
Options listing (LIST: setup function) .....	3-11, 3-22
Options saving (SAVE: setup function) .....	3-11, 3-22
Page length (PAGE LG: setup item) .....	3-15
Paper bail lever .....	1-6
Paper jam .....	4-2
Paper loading .....	2-5, A-4
Paper path lever .....	1-6
Paper-out condition	
Detection (PPR OUT: setup item) .....	3-19
Resuming printing .....	A-5
Paper requirements .....	
Paper tearing .....	2-11
Paper thickness lever .....	2-13
Paper width (WIDTH: setup item) .....	3-17
Parallel interface	
Connector .....	1-10, C-2
Setup .....	Q-4
Specifications .....	C-1
Perforation cut and tie .....	2-19
Perforation skip (PRF SKP: setup item) .....	3-17
Platen knob .....	1-6, 2-8, 2-10
Power cord	
Connection .....	1-8
Received items .....	1-2
POWER indicator .....	3-1
Power outlet .....	1-8
Power switch .....	1 6
Preparing printer for host operation .....	
Prestige elite	
Font .....	B-3
Selection (PRSTG12: setup option) .....	3-14

Print area .....	2-16, 2-17
Printer care .....	4-1
Printer elements .....	1-5
Printer's feature	
Changing procedure .....	Q-6
Factory setting .....	Q-5, 3-9
Printer specifications .....	E-1
Print font (FONT: setup item) .....	3-14
Print head gap adjustment .....	2-12
Printing direction (PRT DIR: setup item) .....	3-19
Print position adjustment .....	2-8, 2-10
Print quality (QUALITY: setup item) .....	3-14
Proportional spacing (PROP SP: setup option) .....	3-14
Protocol (PROTOCOL: setup item, serial) .....	3-21, C-15
Publications .....	SUPPLIES, OPTIONS, & PUBLICATIONS
Quality of printing (QUALITY: setup item) .....	3-14
Quick start procedure .....	Q-1
Quiet printing (QUIET: setup option) .....	3-19
Rear cover .....	1-6
view of printer .....	1-7
Received items .....	1-2
Removing paper jam .....	4-2
Repacking the printer .....	4-8
Replacing ribbon cassette .....	2-5
RESET button .....	3-4
Resetting data in buffer .....	3-4
Resident font tables .....	B-1
Reverse Channel (RC) protocol .....	C-16
Right end carriage return (RGHTEND: setup item) .....	3-17
Ribbon cassette	
Installation .....	2-1
Received items .....	1-2
Replacement .....	2-5
Ribbon paths .....	2-4
RS-232C serial interface	
Cable configuration .....	C-11
Connection .....	1-10
Selection (SERIAL: setup option) .....	3-20
Specifications .....	C-7

Select menu (SEL.MENU: setup function) .....	3-11, 3-12
Self-test	
Operation .....	Q-3, 1-9, 3-24
Paper size .....	1-9
Print pattern .....	1-9
Selection (SELF TST: setup function) .....	3-17
Stopping .....	Q-4
Serial data format .....	C-11
Serial interface	
Cable configuration .....	C-11
Connector .....	1-10, C-9
Setup items .....	3-20
Specifications .....	C-7
SETUP indicator .....	3-2
Setup items	
Baud rate (serial) .....	3-21
Buffer allocation .....	3-19
Buzzer .....	3-19
Character attribute .....	3-15
Character sets .....	3-16
Character spacing .....	3-14
Color print .....	3-17
CR code definition .....	3-17
Cut sheet feeder .....	3-20
Data format (serial) .....	3-20
DC1/DC3 code .....	3-17
Duplex mode .....	3-21
Emulation .....	3-15
Font source .....	3-14
Graphic line feed .....	3-16
Interface type .....	3-20
Language .....	3-16
Left end position offset .....	3-15
LF code definition .....	3-17
Line spacing .....	3-14
Page length .....	3-15
Paper-out detection .....	3-19
Paper width .....	3-15
Perforation skip .....	3-17
Print quality .....	3-14
Printing direction .....	3-19
Protocol (serial) .....	3-21

Right end carriage return (auto CR) ..... 3-17

Speed limitation control ..... 3-19

Top margin ..... 3-16

Word length ..... 3-19

Zero font ..... 3-17

Up mode

  Display transition ..... 3-7

  Function, item, option ..... 3-6, 3-11, 3-14

  Structure ..... 3-7

7/8 bit ASCII code See word length ..... 3-19

Shipping restraints ..... 1-3

Software setup ..... APPLICATION SOFTWARE SETUP

Specifications

  Interface ..... C-1

  Paper ..... 2-14

  Printer ..... E-1

Speed limitation control (SPEED: setup item) ..... 3-19

Supplies ..... SUPPLIES, OPTIONS, & PUBLICATIONS

Switching continuous forms to cut sheet paper ..... 2-10

Tear bar ..... 2-11

  Turning off continuous forms ..... 2-11

Top cover ..... 1-6

Top margin (TOP MRG: setup item) ..... 3-16

Top of form

  Adjustment (TOF-ADJ: setup function) ..... 3-11, 3-28

  Print area ..... 2-16, 2-17

Troubleshooting ..... 4-6

Unidirectional printing (UNI-DIR: setup option) ..... 3-19

Unloading continuous forms ..... 3-5

Unpacking ..... 1-1

Vertical alignment (V-ALNMNT: setup function) ..... 3-11, 3-27

Word length (WORD LG: setup item) ..... 3-19

XON/XOFF protocol ..... C-15

Zero font (ZEROFNT: setup item) ..... 3-17

